

3000SP Storage inverter

User Manual



Table of Contents

1.	Introduction	7
2.	Preliminary safety instructions	8
2.1.	General safety instructions	9
2.2.	Instructions on battery installation and maintenance.....	9
2.3.	Symbols on the inverter.....	10
3.	Installation.....	12
3.1.	Product Overview.....	12
3.2.	Contents of the packaging.....	13
3.3.	Installation environment	14
3.4.	Installation tools	15
3.5.	Wall installation position	16
3.6.	Assembly instructions.....	17
4.	Electrical connections.....	19
4.1.	Connecting the battery.....	20
4.2.	Connecting a Pylontech battery	21
4.2.1.	Connecting a single battery	21
4.2.2.	Connecting multiple batteries in parallel.....	22
4.3.	Connecting a WeCo battery	24
4.3.1.	Connecting a single battery	24
4.3.2.	Connecting multiple batteries in parallel.....	25
4.4.	CT / Battery Communication / RS485 Connections.....	28
4.5.	Connecting to the grid	33
4.6.	Connecting the critical load (EPS function)	34
5.	Buttons and indicator lights	36
5.1.	Buttons.....	36
5.2.	Indicator lights	36
5.3.	Operating status.....	37

6.	Operation.....	38
6.1.	Preliminary checks	38
6.2.	Procedure for initial set-up	38
6.3.	“FREEZING” current sensors	41
6.4.	Menu	44
6.4.1.	Settings.....	45
6.4.2.	Event List.....	59
6.4.3.	System Information	60
6.4.4.	Software Update.....	61
6.4.5.	Energy Statistics (Energy statistic).....	63
7.	Connections in three-phase mode	64
7.1.	CT / Battery Communication / RS485 Connections.....	66
7.2.	Operation	69
7.2.1.	Preliminary checks	69
7.2.2.	First start-up of the inverter	70
7.2.3.	“FREEZING” current sensors	72
7.2.4.	Setting CTpv in three-phase mode	75
8.	Verification of proper functioning	77
8.1.	Checking the settings	79
9.	Technical specifications	82
.....	82
10.	Troubleshooting and maintenance.....	83
10.1.	Troubleshooting.....	83
10.2.	Maintenance	88
11.	Uninstalling.....	90
11.1.	Uninstallation steps.....	90
11.2.	Packaging.....	90
11.3.	Storage	90
11.4.	Disposal	90
12.	Monitoring systems.....	92
12.1.	External Wi-Fi adapter.....	92

12.1.1.	Installation	92
12.1.2.	Configuration	93
12.1.3.	Verification	102
12.1.4.	Troubleshooting.....	105
12.2.	Ethernet adapter.....	110
12.2.1.	Installation	110
12.2.2.	Verification	112
12.2.3.	Troubleshooting.....	114
12.3.	4G adapter	115
12.3.1.	Installation	116
12.3.2.	Verification	118
13.	Warranty terms and conditions	121

General instructions

This manual contains important safety instructions that must be followed during installation and maintenance of the equipment.

Please keep these instructions!

This manual must be considered an integral part of the equipment, and must be available at all times to everyone who interacts with the equipment. The manual must always accompany the equipment, even when it is transferred to another user or plant.

Copyright statement

Copyright of this manual belongs to Zucchetti Centro Sistemi S.p.A. No part of this manual (including the software, etc.) may be copied, reproduced or distributed in any form or by any means without the permission of Zucchetti Centro Sistemi S.p.A. All rights reserved. ZCS reserves the right to final interpretation. This manual is subject to change based on feedback from users, installers or customers. Please check our website at <http://www.zcsazzurro.com> for the latest version.

Technical support

ZCS offers a support and technical consultancy service accessible by sending a request directly from the website <https://www.zcsazzurro.com/it/support>.

The following toll-free number is available for the Italian territory: 800 72 74 64.

Preface

General information

Please read this manual carefully before installation, use or maintenance.

This manual contains important safety instructions that must be followed during installation and maintenance of the system.

- **Scope**

This manual describes the assembly, installation, electrical connection, commissioning, maintenance and troubleshooting of the ZCS 3000SP storage inverter.

Keep this manual so that it is accessible at all times.

- **Recipients**

This manual is intended for qualified technical personnel (installers, technicians, electricians, technical support personnel or anyone who is qualified and certified to operate a photovoltaic system), who are responsible for installing and starting the inverter in the photovoltaic energy system and for operators of the photovoltaic system.

1. Introduction

The 3000SP storage inverter is an AC-connected bidirectional electrical energy inverter developed for photovoltaic production and domestic storage systems. The system can be combined with WeCo or Pylontech batteries offered in kit form by ZCS Azzurro. The system is also compatible with all existing photovoltaic inverters and modules and can be integrated into an existing system or installed together with a new photovoltaic system.

The product is equipped with an LCD display and keypad, simple and user-friendly interface that records data on the energy produced and any errors for quick and easy assistance and support.

The 3000SP storage system is the best solution to optimise the use of energy produced by renewable sources. The system is able to manage the bidirectional flow of electricity, while controlling the power produced by the photovoltaic modules, the power stored and taken from the battery, the power exchanged with the electrical grid and the power supplied to utilities.

The inverter is able to operate in different working modes: automatic, forced charging from the grid and the possibility to charge/discharge the battery according to your needs. In automatic mode, the 3000SP inverter is able to independently optimise the use of the renewable energy and batteries, minimising the purchase of electricity from the national grid. The second mode forces the energy to be drawn from the grid to charge the battery, when needed. The third option allows programming the battery discharge hours and modes, giving the customer complete flexibility.

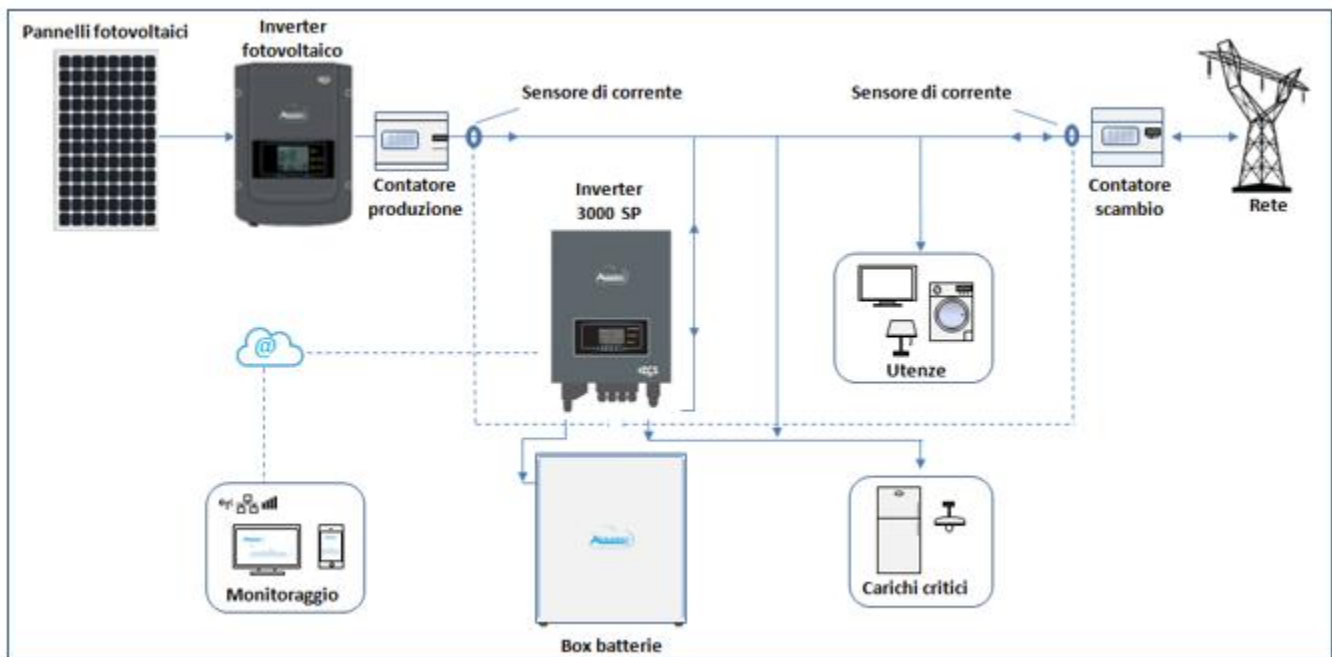

Figure 1 - Schematic diagram of a single-phase system powered by a renewable source and equipped with a 3000SP storage inverter

2. Preliminary safety instructions

Before installation, please read this manual carefully and make sure you fully understand its contents. The 3000SP inverter strictly complies with the safety, design and testing regulations provided for by the national standards.

During installation, operation and maintenance, operators must carefully observe the local safety standards.

Improper use may result in electrical shock and harm and damage to persons, the equipment and its components.

Contact the nearest authorised service centre for any repairs or maintenance. Contact your distributor for information on the nearest authorised service centre. DO NOT carry out repairs yourself, as this may result in injury or damage.

Ensure that the operator has the necessary skills and training to operate the equipment. Personnel responsible for the use and maintenance of the equipment must be qualified and capable of performing the activities described, and must also have appropriate knowledge on how to correctly interpret the contents of this manual. For safety reasons, this inverter can only be installed by a qualified electrician with the necessary training and/or skills and knowledge. Zucchetti Centro Sistemi S.p.A. declines all responsibility for damage to property or personal injury caused by incorrect use of the device.

Install and start the inverter according to the following instructions. Place the inverter on suitable load-bearing supports with sufficient load capacity (such as walls or racks) and make sure that the inverter is positioned vertically. Choose a suitable location for the installation of the electrical equipment. Make sure there is sufficient space for heat dispersion and to accommodate future maintenance. Maintain adequate ventilation and ensure that there is enough air circulation for cooling.

If you have problems with the packaging that could damage the inverter or if you find any visible damage, immediately notify the transport company. If necessary, request assistance from an installer of photovoltaic systems or from Zucchetti Centro Sistemi SpA. Transport of the equipment, especially by road, must be carried out with vehicles suitable to protect the components (in particular, electronic components) against violent knocks, humidity, vibrations, etc.

2.1. General safety instructions

- Installation and maintenance of the system must be carried out by qualified and certified electricians in compliance with national regulations.
- The 3000SP inverter must only be installed by qualified personnel and only after obtaining the appropriate authorisations and permits as required by the local regulations.
- DO NOT place explosives or flammable materials (e.g. gasoline, kerosene, oil, wood, cotton or similar) near the batteries or the 3000SP inverter.
- Before any maintenance, disconnect the DC (battery) and AC (grid and loads) connections, then wait at least 5 minutes to allow the capacitors to discharge and to prevent accidental electrical discharges.
- The 3000SP inverter must be completely disconnected (DC and AC side) during maintenance.
- The 3000SP inverter may reach high temperatures during operation. Switch off the inverter and wait for it to cool down before maintenance.
- Keep children away from the batteries and inverter.
- Do not open the front cover of the inverter. This will void the product warranty.
- Damage to the inverter caused by incorrect installation, maintenance or use will not be covered by warranty.

2.2. Instructions on battery installation and maintenance

- At the time of delivery, the battery is charged to at least 60%. Take all appropriate measures to prevent the battery from short-circuiting during transport and installation.
- Place the battery in a well-ventilated place. Do not install in a confined space or areas with poor air circulation. The battery may be damaged if not properly ventilated.
- Do not place the battery in very hot places, in direct sunlight or near heat sources. Overheating of the

battery may damage it or cause it to catch fire.



- To prevent voltage drops, the connection wires of the battery must be as short as possible, depending on the installation requirements.
- Use a tester to check the battery voltage and the anode and cathode polarity before switching on the system. Make sure that the connections are correct as described in this manual and that the polarity of the connections have not been reversed.
- The switched-off battery should be temporarily stored with the battery completely disconnected from the inverter and the loads, in a cool, dry and ventilated place.
- Battery maintenance personnel must have the technical knowledge and skills to service the battery.
- Batteries connected in parallel must be of the same model and have the same firmware version. This requirement must be taken into account by the designer or installer when setting-up the system or when the batteries are replaced and the storage system is modified. In the case of parallel connections of multiple Pylontech or WeCo batteries, please refer to the appropriate procedure available at www.zcsazzurro.com.







Attention: Do not open or damage the batteries. Electrolytes inside the battery can be toxic and cause damage to the skin and eyes.

- Attention: Carefully follow these instructions when installing and servicing the battery.
 - a) Take off any watches, rings or other metal objects that you may be wearing.
 - b) Only use tools with insulated handles.
 - c) Wear rubber gloves and shoes.
 - d) Do not place tools or metal objects on top of the battery.
 - e) Switch off the 3000SP inverter and the batteries before connecting or disconnecting the terminals.
 - f) Isolate the positive and negative poles of the battery from the ground.

2.3. Symbols on the inverter

Some safety symbols are located on the inverter. Read and understand the contents of the symbols before installing the inverter.

 	<p>Residual voltage may be present on the inverter! Before opening the inverter, wait 5 minutes to ensure that the capacitors are completely discharged.</p>
---	--

	<p>Beware of high voltage</p>
	<p>Beware of high temperatures</p>
	<p>Complies with the European Standards (CE)</p>
	<p>Ground connection point</p>
	<p>Read this manual before installing the inverter.</p>
	<p>Indication of the allowable temperature range</p>
	<p>Degree of protection of the equipment according to the IEC 70-1 standard (EN 60529 June 1997).</p>



3. Installation

3.1. Product Overview

Each 3000SP inverter has been rigorously inspected prior to packaging and delivery.

Do not flip over, shake or jerk the packaging during transport.

Before opening the box, please check that the packaging of the product is intact and has not been damaged or tampered with.

Once the packaging has been opened, please check the condition of the inverter and its accessories, making sure that they have not been damaged during transport (in particular, carefully check the mechanical components, display and connections on the terminal block).

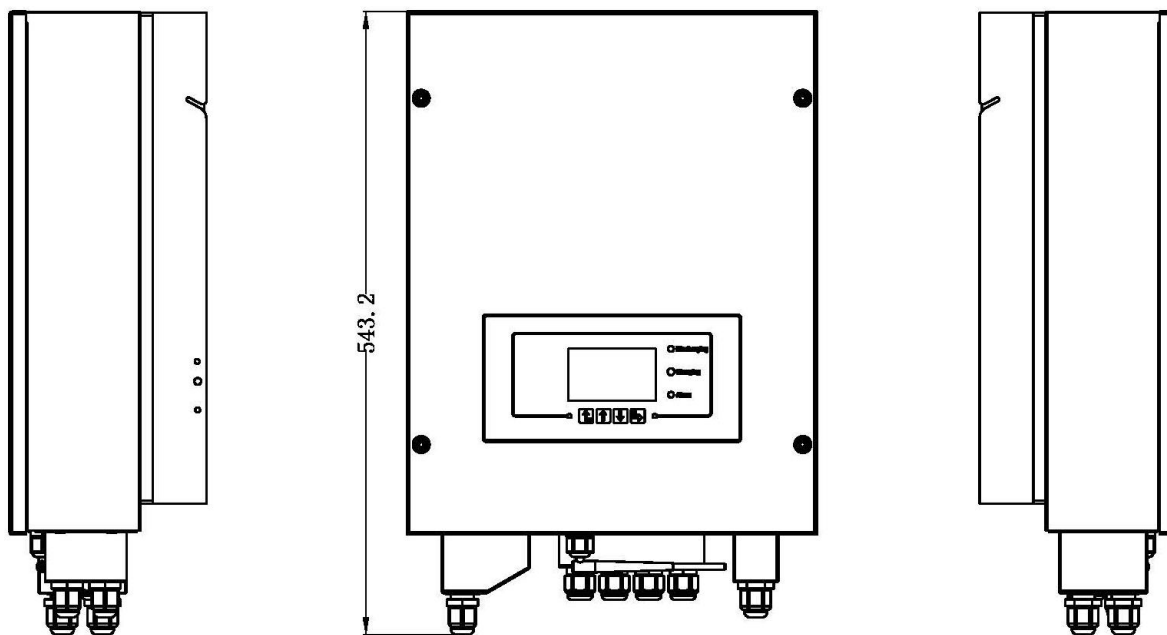
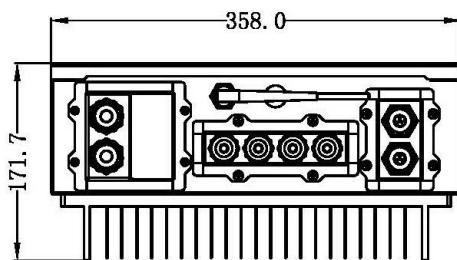

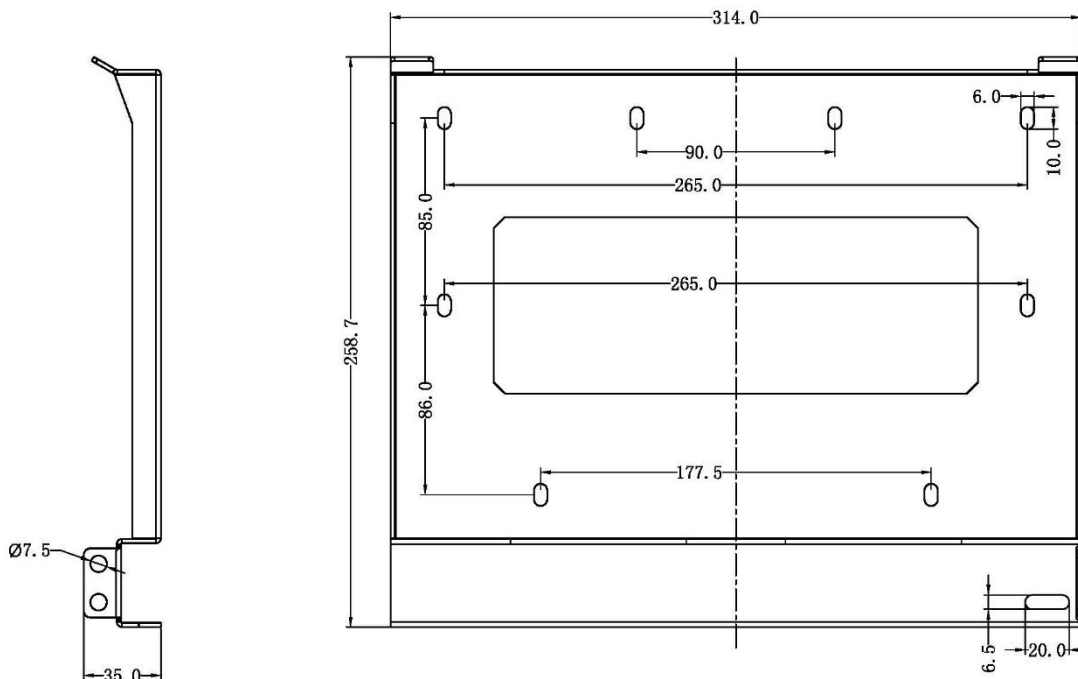
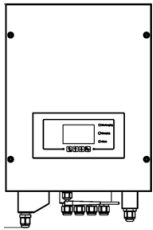
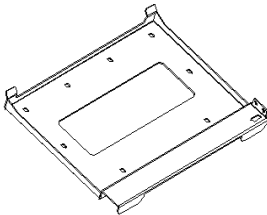
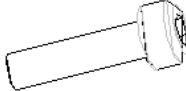
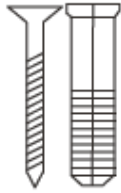
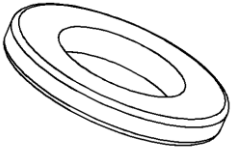
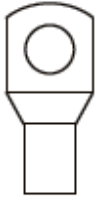

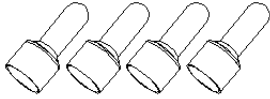

Figure 2 - Views of the 3000SP storage inverter and mounting bracket

3.2. Contents of the packaging

Carefully check the contents of the packaging before installation, making sure that no element inside the packaging is missing or damaged.

The package should contain the following components:

 1 Storage inverter	 1 mounting bracket	 2 M5 screws	 8 expansion plugs and screws
 8 M6 flat washers	 2 DC terminals	 6 AC terminals	 4 terminal caps





 <p>2 current transformers</p>	 <p>2 CT terminals</p>	 <p>1 Pylontech battery communication cable</p>	 <p>1 Warranty Registration</p>
 <p>2 warranty certificate</p>	 <p>1 user manual</p>		

Figure 3 - Components and accessories inside in the packaging



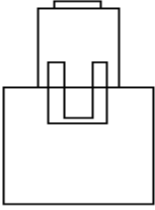
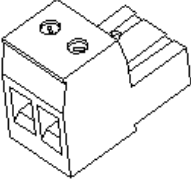
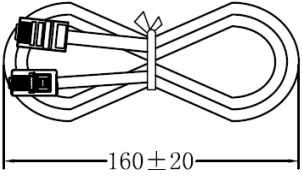

3.3. Installation environment

For correct functioning of the system, the inverter and batteries must be installed in an environment with the following characteristics:

- Dry, clean and sheltered place.
- Ambient temperature between -25°C and +60°C.
- Relative humidity between 0% and 100% (non-condensing).
- Presence of independent air intakes at the entrance and exit of the room.
- No flammable or explosive materials in the vicinity.
- Altitude below 2000 metres.
- Connection to the electrical grid with over-voltage category CATII and CATIII.
- For further details on installation, please contact technical assistance.

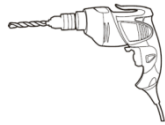
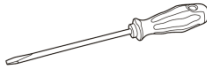
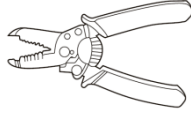
3.4. Installation tools

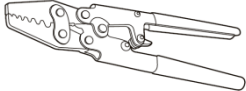
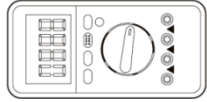
The following tools are required for installation of the inverter and batteries. Therefore, they must be prepared before installation.

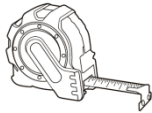
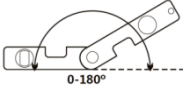
No.	Tool	Function
1	 Drill Recommended drill bit: 6mm	To drill holes in the wall for fixing the bracket
2	 Screwdriver	To screw and unscrew screws for the various connections
3	 Wire stripper	To prepare the cables for wiring
4	 4 mm Allen key	To screw the inverter to the wall-mounting bracket
5	 Crimping tool	To crimp the power cables
6	 Multi-meter	To check the voltage and current values
7	 Marker pen	To mark the wall for better fixing precision
8	 Measuring tape	To measure distances
9	 Level	To make sure the bracket is level



10		ESD gloves	Protective clothing
11		Safety goggles	Protective clothing
12		Protection mask	Protective clothing

Figure 4 - Tools required for installing the 3000SP inverter and batteries

3.5. Wall installation position

The 3000SP storage inverter must be installed vertically on the wall (to ensure rapid and effective heat dissipation) or at an inclination not exceeding 15°.

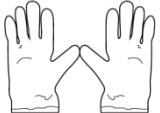
Also make sure that the position where the inverter is installed is not directly exposed to sunlight or subject to the accumulation of snow so as to prevent damage to the internal components of the machine.

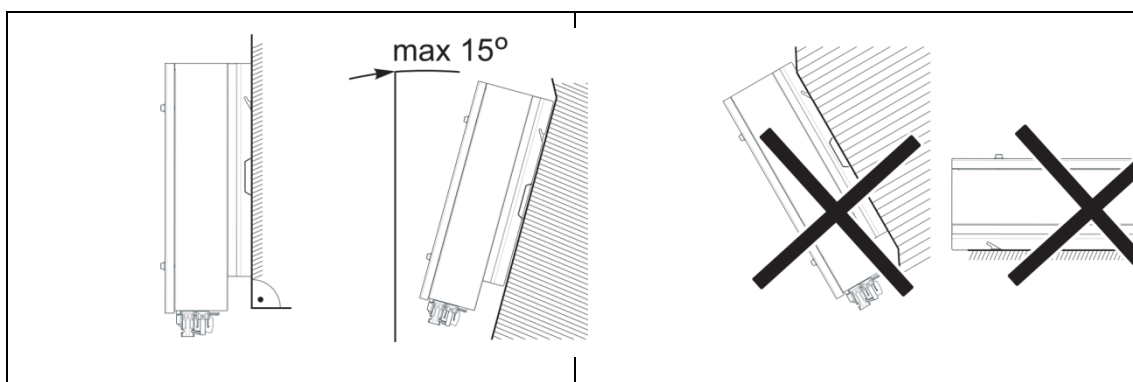

Figure 5 - Correct installation of the 3000SP inverter

3.6. Assembly instructions

- 1) Correctly position the mounting bracket on the wall using a level to ensure that it is straight; mark the eight holes using a suitable marker pen. Drill the eight holes at the points marked on the wall using a 6 mm drill bit.
- 2) Insert the plugs horizontally into the holes, paying attention to the force and depth with which they are inserted.
- 3) Fix the mounting bracket to the wall using the screws and flat washers supplied.

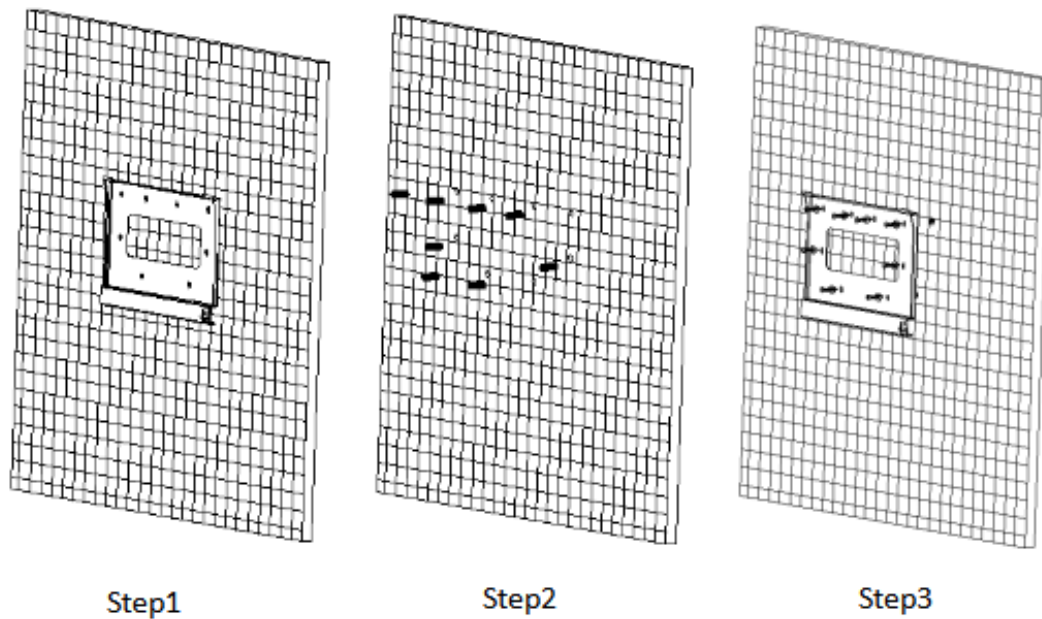

Figure 6 - Instructions for fixing the bracket to the wall

- 4) Position the 3000SP storage inverter on the mounting bracket and secure it with the mounting bolt supplied.
- 5) Secure the grounding connection of the 3000SP by means of the bolt supplied and using the appropriate hole in the heat sink.
- 6) (OPTIONAL) Depending on the customer's requirements, the 3000SP inverter can be locked to the mounting bracket with a safety lock (not supplied with the kit).

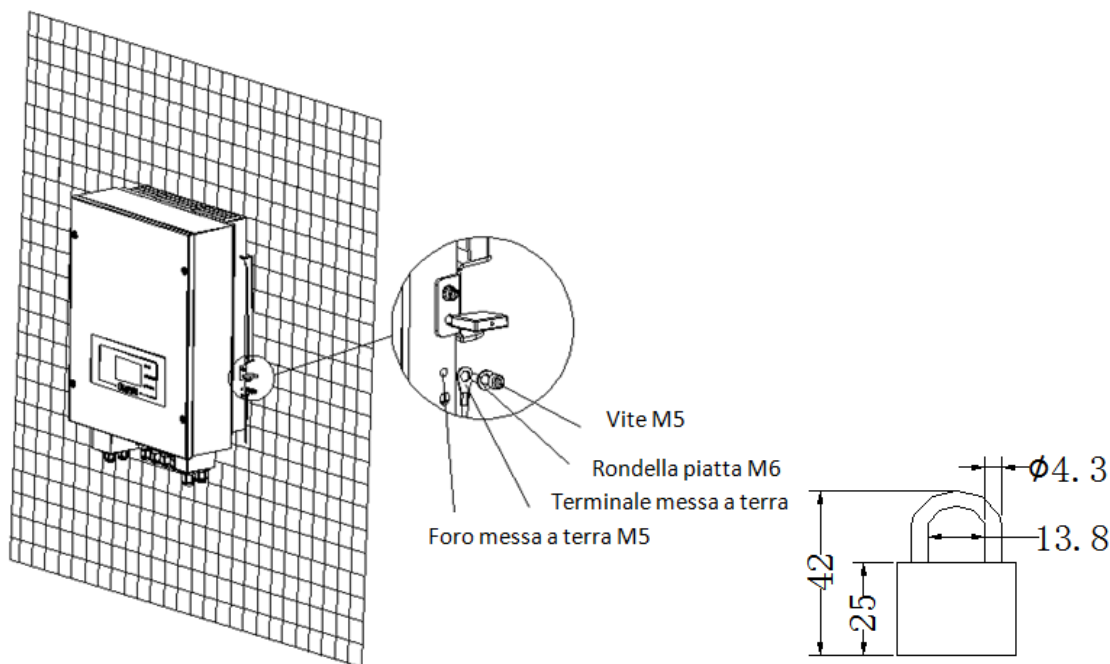

Figure 7 - Possibility of locking the inverter to the staff with a lock

Note: For safety reasons, ZCS Spa and/or its partners may not carry out any technical repairs or maintenance work, or move the inverter or battery packs from and to the ground if they are installed at a height of more than 180 cm from the ground.

Inverters and/or battery packs installed at higher heights must be moved to the ground before they can be repaired or serviced.

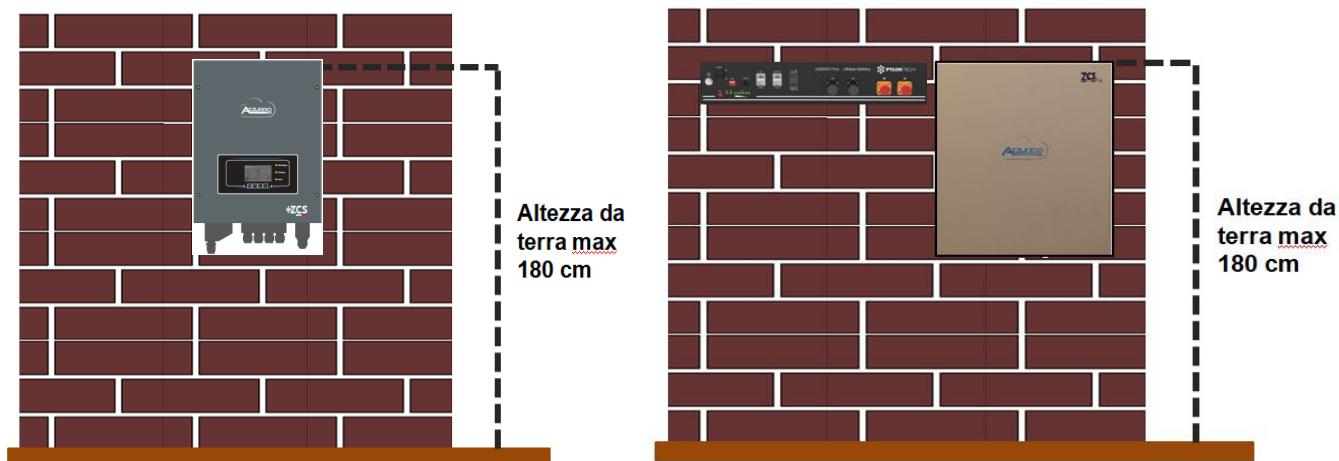

Figure 8 - Instructions for installing the storage inverter and battery pack

4. Electrical connections

- Carefully assess the risks deriving from electric shocks and chemical hazards!
- Use a multi-metre to check the DC polarity of the battery and cables before connecting the power supply between the batteries and inverter.

NOTE: an inverted polarity connection may cause irreparable damage to the inverter and batteries.

Note: the Pylontech batteries, as well as the WeCo batteries do not require a disconnecting device for connecting to the storage inverter. The Cable kit, which includes crimped power cables for connecting the Pylontech batteries to the 3000SP storage inverter, is supplied separately. It is recommended to ensure that your storage kit is equipped with this accessory. In the case of Pylontech and WeCo batteries, the connection kit is already inside the package.

- A 25 AC disconnecting device (circuit breaker) must be installed between the 3000SP inverter and the power grid. It is also recommended to use a differential with a trip threshold of 30 mA between the 3000SP inverter and power grid.
- For safety and proper functioning of the system, it is important to use a cable of the appropriate type and size for the electrical connections.
 - Battery connection: DC cable with cross-section of AWG8 or AWG6 (supplied).
 - Grid or load connection: AC cable with cross-section of AWG12.

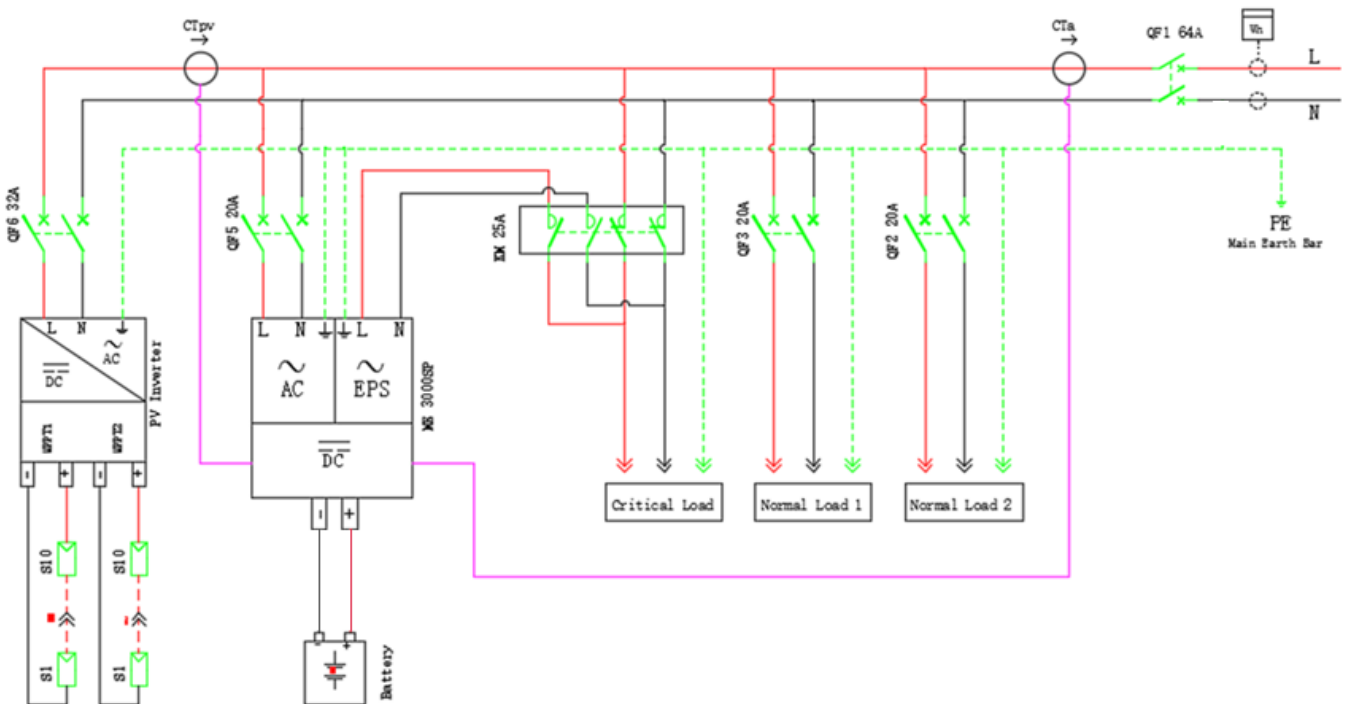

Figure 9 - Detailed diagram of the connections of a single-phase system

4.1. Connecting the battery

1. Unscrew the 4 screws of the cover (A) with a star screwdriver (figure 10).
2. Remove the waterproof cover (B), loosen the cable gland (C), and then remove the stopper (G).
3. Route the battery cables (F) through the cable gland, then connect them using the OT terminal (E) supplied; the terminal must be screwed to the terminal block using the special star screws. The other end of the cable, which has the quick coupling for the batteries, must be positioned in the relative positive and negative terminals of the installed battery.
4. Replace the waterproof cover and secure it with the 4 screws; tighten the cable gland.

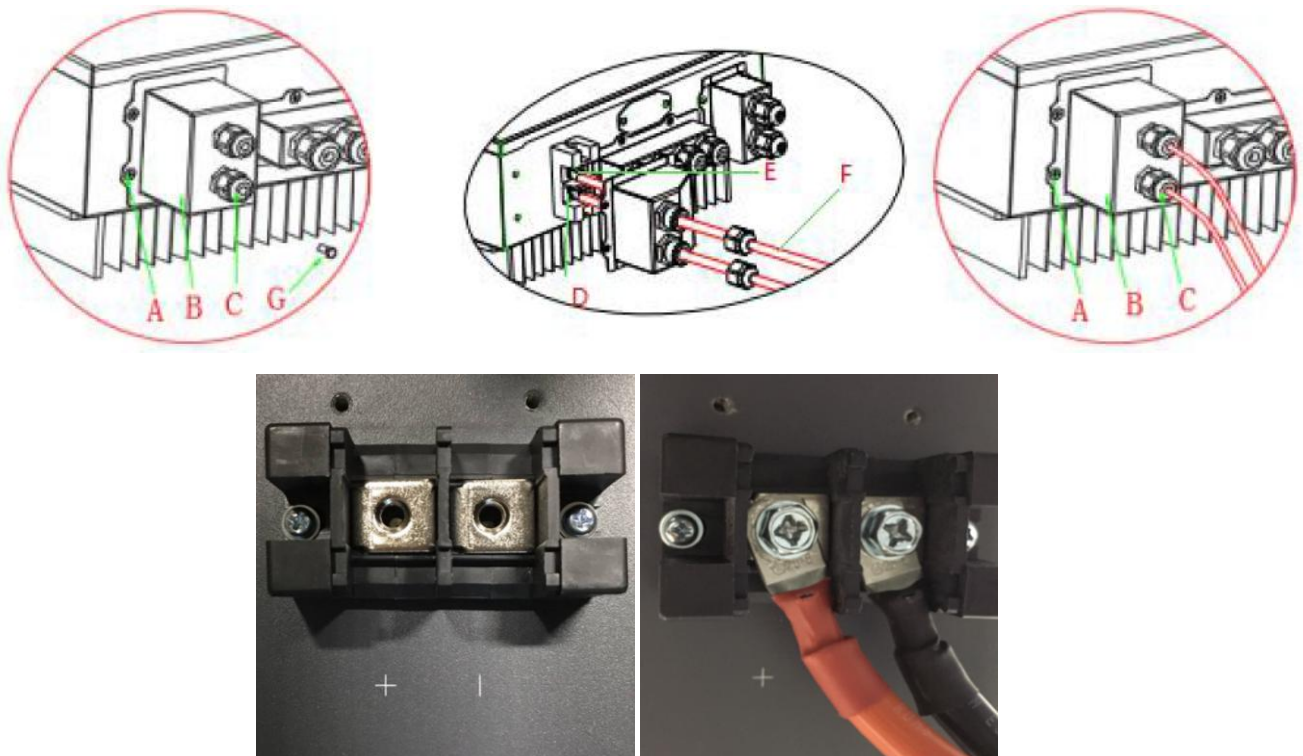

Figure 10 - Connecting the power line of the battery

!!!PLEASE NOTE!!!

If the storage capacity needs to be increased by adding one or more batteries to an existing system, make sure that all the batteries (installed and to be installed) are fully charged.

To check the charge status of each battery, connect them one at a time to the inverter and view the charge level on the display (all the instantaneous information can be accessed by pressing the “Down” key from the main menu).

The batteries can be recharged from the excess photovoltaic production or by using the forced charge mode indicated in the “% charge mode” section of this manual.

4.2. Connecting a Pylontech battery

4.2.1. Connecting a single battery

This cable must be connected to the battery by inserting the RJ45 (8 pin) plug into the appropriate connection:

1. In the case of Pylontech batteries, insert the plug into the CAN port of the single battery.



Figure 11 - Pylontech communication cable to be inserted into the battery communication input

2. Ensure that the order of the DIP switches remains at the factory settings (all down in the OFF position).
3. Connect the ground cable to the battery through the threaded hole.

NOTE: When connecting Pylontech batteries, use the communication cable contained in the inverter kit, as shown in the figure.



Figure 12 - Connecting the communication cable to the Pylontech battery

4.2.2. Connecting multiple batteries in parallel

If multiple batteries are present, check the parallel connections between one battery and another.

- a. In the case of Pylontech batteries, connect one of the two power cables (e.g. the positive, orange one) to the master battery, inserting the fast contact into the appropriate terminal; then connect the other cable (e.g. the negative, black one) to the last battery of the pack, as shown in the figure below. Finally, run the batteries in parallel using the short jumpers (supplied with the battery) or those with a length of 0.6 m or 1.5 m (available on request, codes ZST-CABLE-0.6M and ZST-CABLE-1.5M), connecting respectively the positive and negative polarities of one battery with those of the next battery.



Figure 11 - Connecting three Pylontech batteries in parallel

The communication cables must be connected starting from the master battery and inserting the short jumper (supplied with the battery) or a jumper with a length of 0.6 m or 1.5 m (available on request, codes ZST-CABLE-0.6M and ZST-CABLE-1.5M) in the LINK connection PORT; insert this cable in LINK CONNECTION PORT 0 of the second battery, which will be called Slave 1. If additional batteries are present, a new jumper must be inserted into LINK CONNECTION PORT 1 of the Slave 1 battery; insert the free end of this cable into the third battery, called Slave 2. This procedure will be repeated for all the elements of the battery pack.

In the end, all the LINK PORTS will be occupied by the communication cable, except for the master battery (LINK PORT 0 free) and the last Slave battery (LINK PORT 1 free).

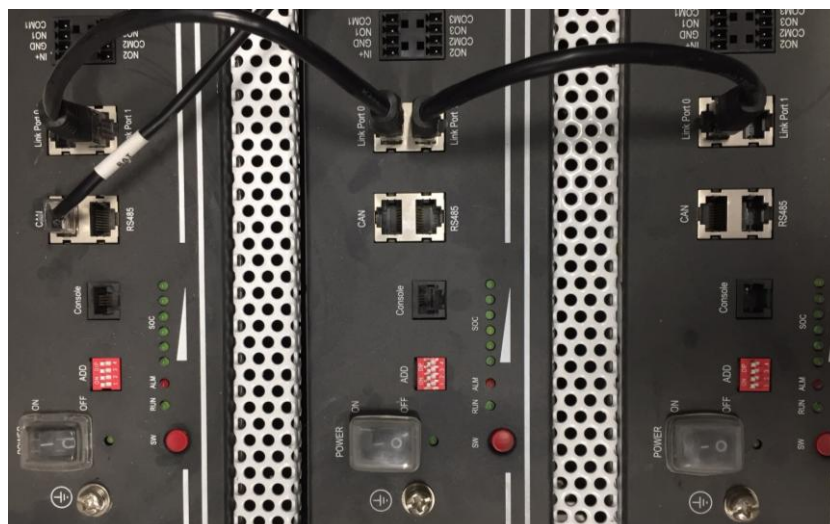

Figure 14 - Connecting the communication cable between three Pylontech batteries

NOTE: the position of the DIP switches (white on a red background, as shown in the figure below) should not be changed. If it is changed by accident, contact the ZCS Service Centre at the toll-free number 800 72 74 64 (available on in Italy) or open a ticket by going to the support section of our website: <https://www.zcsazzurro.com/it/support>.

4.3. Connecting a WeCo battery

4.3.1. Connecting a single battery

This cable must be connected to the battery by inserting the RJ45 (8 pin) plug into the appropriate connection:

- In the case of WeCo batteries, insert the plug into the BMS CAN port of the single battery.



Figure 15 - Communication cable between the inverter and WeCo battery

- b. Make sure that the DIP switches are set as shown in the figure.
- c. Connect the ground cable to the battery through the threaded hole.

NOTE: To connect the WECO batteries, use the blue or grey communication cable contained in the battery kit.

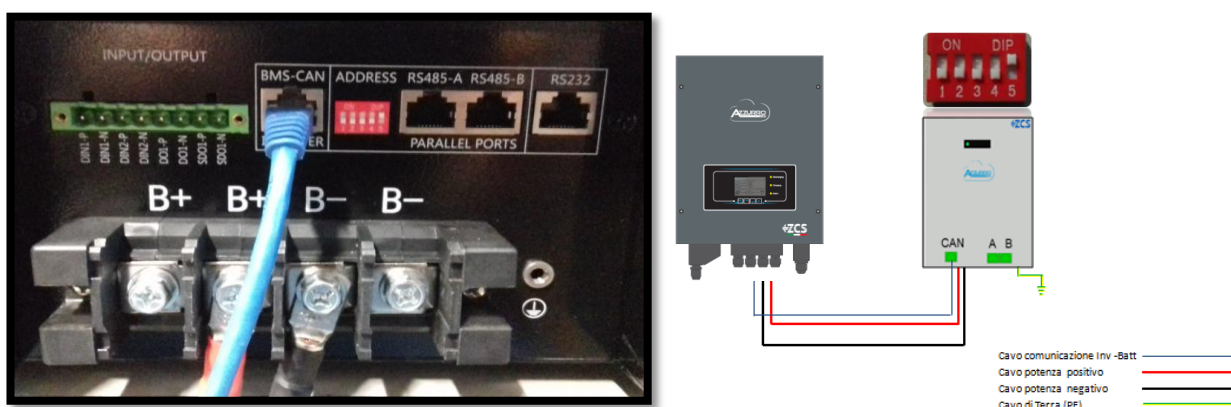

Figure 16 - Connecting the communication cable to the WeCo battery

4.3.2. Connecting multiple batteries in parallel

If multiple batteries are present:

- a. Check that the batteries have the same voltage level by switching them on and disconnecting them one at a time, measuring the + and - terminals with the tester. Make sure that the difference between the voltages of all the batteries is less than 2 Volts.
- b. Set the DIP switches correctly according to the number of batteries connected, as shown in the figure (warning: only make changes when the battery is switched off).
- c. Connect the communication cable inserted in the CAN port of the inverter to the CAN-BUS port of one of the batteries, this will now become the MASTER battery.
- d. The MASTER must be connected to the communication cable inside the battery box starting from the **RS485-B** port and arriving at the **RS485-A** communication port of the Slave 1 battery. (**Attention: do not connect the RS485-A port to the Master battery**).



Figure 17 – Communication cable between the batteries

- e. In case of additional batteries, the communication cable will be connected as indicated above for the connection of the MASTER battery to SLAVE 1.
- f. The last battery will only have the RS485-A port connected.

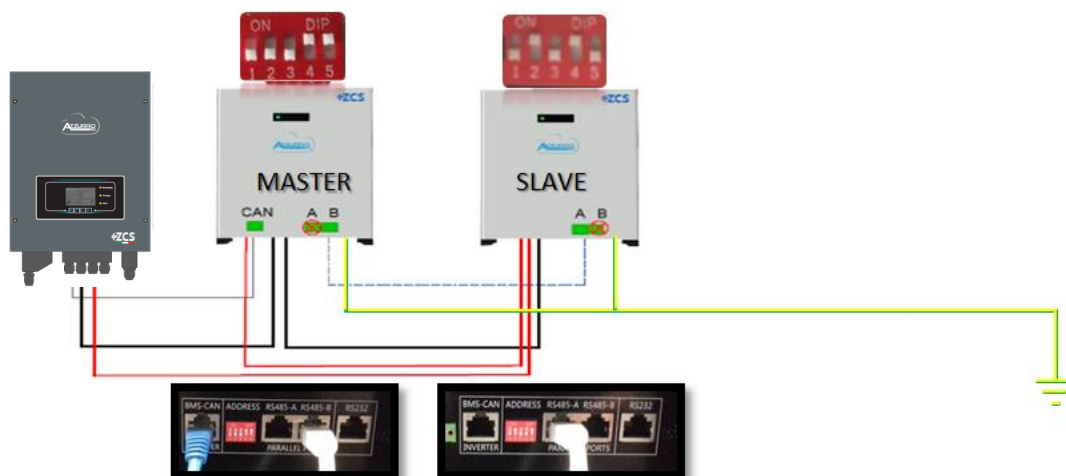

Figure 18 – Parallel connection of two WeCo batteries

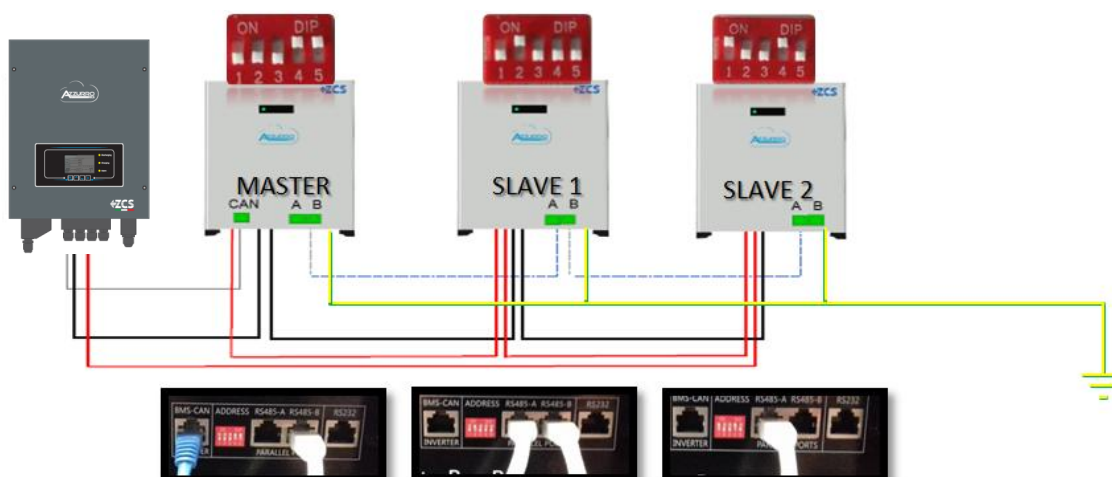

Figure 19 – Parallel connection of three WeCo batteries

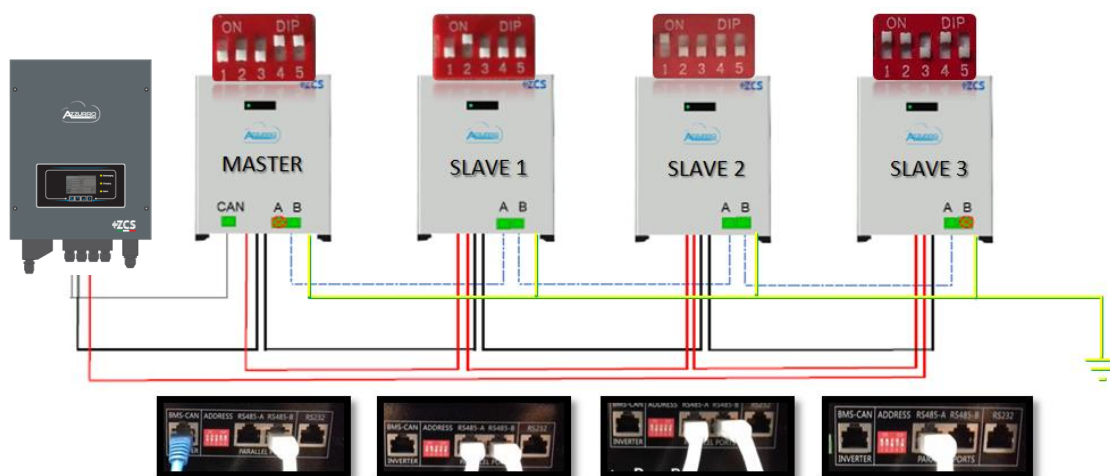

Figure 20 – Parallel connection of four WeCo batteries

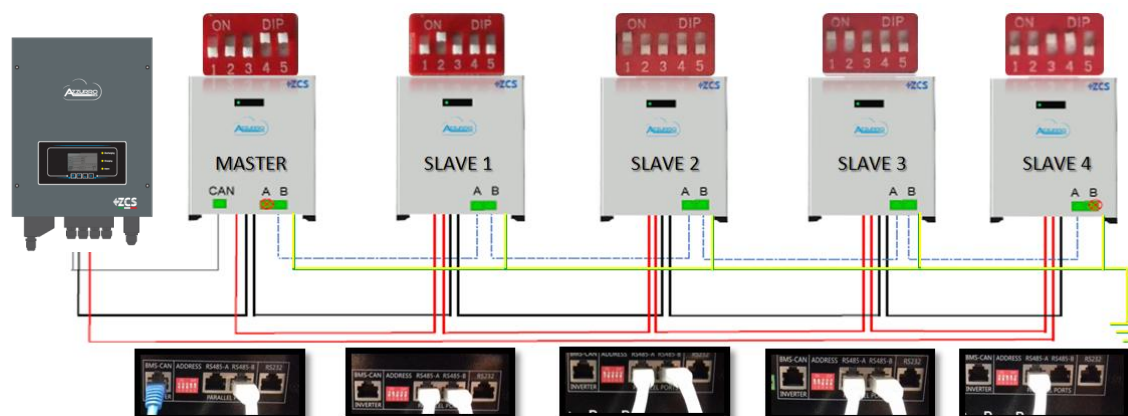

Figure 21 – Parallel connection of five WeCo batteries

4.4. CT / Battery Communication / RS485 Connections

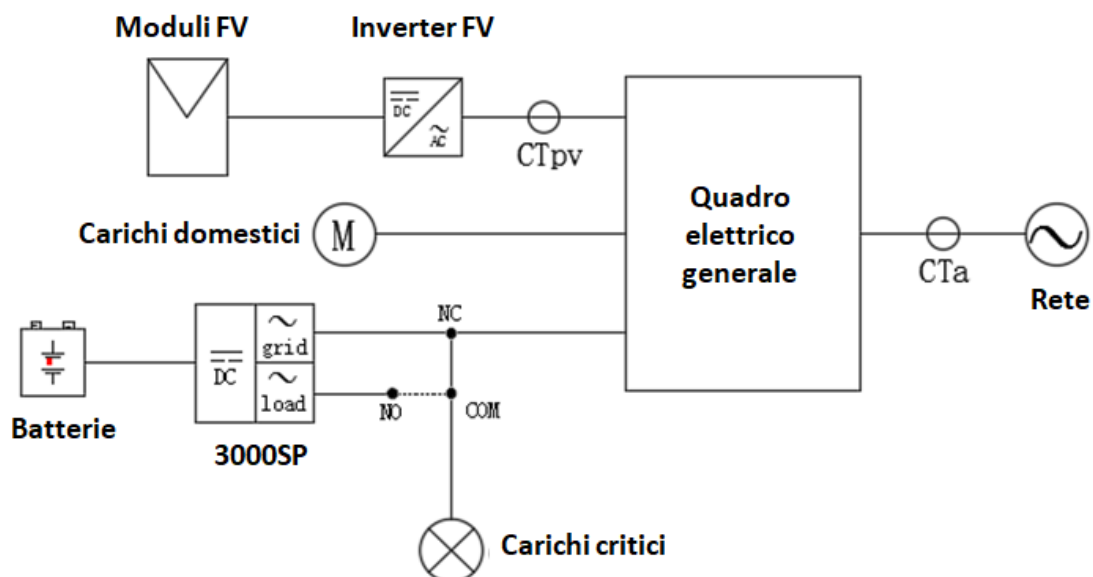
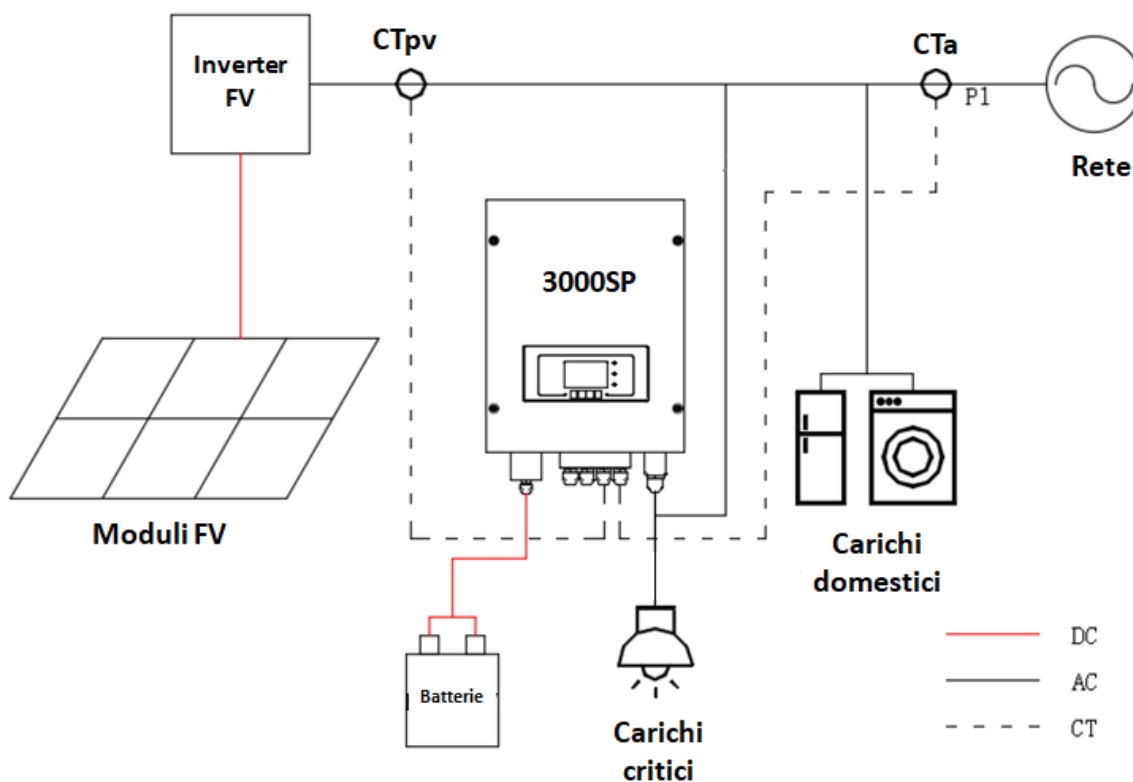

Figure 22 - Wiring diagram of the 3000SP storage inverter in a system powered by renewable energy

- 1) Correctly position the two current sensors (CT):
 - the CTa for measuring the energy exchanged with the grid must be positioned at the output of the exchange meter (utility side) and must include all the phase cables entering or leaving the meter. The CTa will therefore measure the energy taken from and fed into the grid by the photovoltaic system.
 - The CTpv for measuring the photovoltaic production must be positioned on the phase cable exiting the photovoltaic inverter (utility side) or from the production counter, and will only measure the energy generated by the photovoltaic inverter.

- 2) If it is necessary to extend the sensor connection cables, use UTP network cables. If there is electrical/electronic noise near the cable that causes interference, use FTP network cables. The cable can be extended by up to 100 metres with a minimum loss of signal

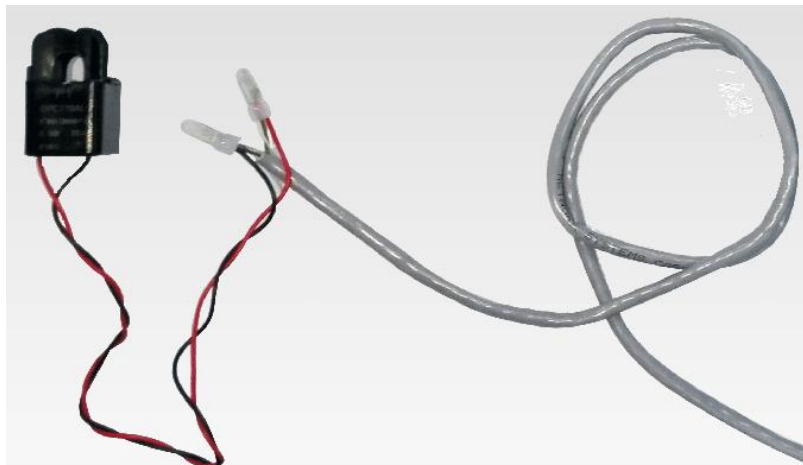

Figure 23 – Extending the cable of the CT current sensor

Below is a reference for connecting the sensors to the CT terminals supplied.

CT cable	Extension (network cable)	Connection to 3000SP
Red	orange / white-orange / brown / white-brown	CT+
Black	green / white-green / blue / white-blue	CT-

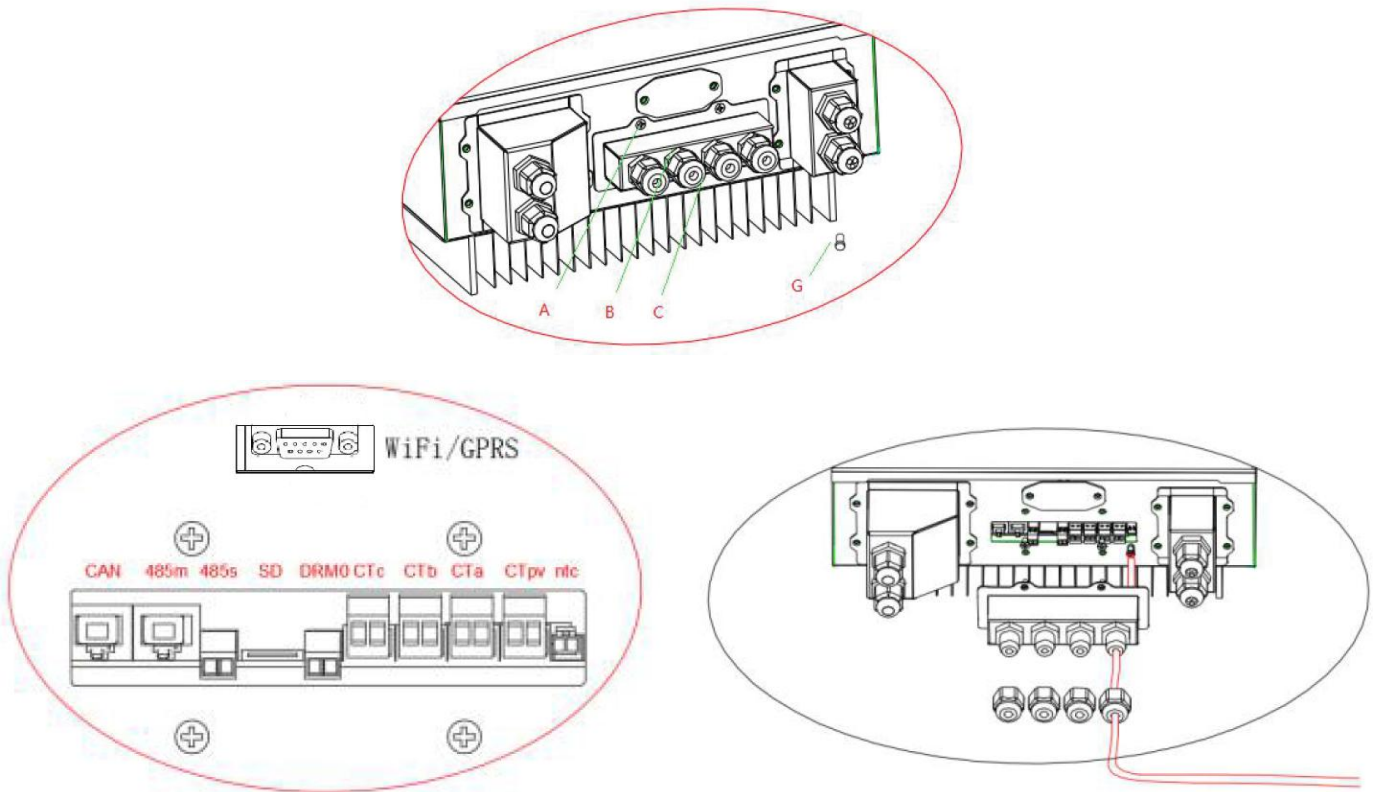

Figure 24 - Connecting the CT cables for the current sensors

- 3) Unscrew the 4 screws (A) of the central cover with a star screwdriver (figure 24).
- 4) Remove the waterproof cover (B), loosen the cable gland (C), and then remove the stopper (G).
- 5) Route the CT cable through the cable gland to the right of the cover, connect the cable to the CT terminal supplied, then insert the CT terminals into the corresponding ports (CTa for the exchange sensor and CTpv for the production sensor).
- 6) If using Pylontech batteries, the communication cable between the inverter and batteries is supplied as an accessory inside the transparent bag in the inverter's packaging. For WeCo batteries, the cable is found inside the battery packaging.
Connect one terminal to the battery (BAT), and the other to the inverter (inverter).
Route the communication cable (inverter side) through the cable gland on the left side of the cover, then insert the connector into the CAN port. Insert the battery-side connector (BAT end) into the CAN port of the PYLONTECH or WeCo battery.
NOTE: for correct connection between the inverter and batteries, please refer to the relevant procedure or manual.



Communication cable between the battery and the 3000SP inverter	CAN communication	
	3000SP	
	CAN port	CANH→pin1 CANL→pin2 GND→pin3
	WeCo	
	CAN port	CANH→pin1 CANL→pin2 GND→pin3

Figure 12 – End of WeCo communication cable with inverter-side terminal in the CAN input

Communication cable between the battery and the 3000SP inverter	CAN communication	
	3000SP	
	CAN port	CANH→pin1 CANL→pin2
	RS485 port	485A→pin3 485B→pin4

	PYLONTECH	
	CAN port	CANH→pin4 CANL→pin5
	RS485 port	485A→pin1 & pin8 485B→pin2 & pin7

Figure 26 – End of Pylontech communication cable with inverter-side terminal in the CAN input

- 7) Replace the waterproof cover and secure it with the 4 screws; tighten the cable gland.
- 8) Below are some simplified diagrams showing the correct and incorrect installation of the current sensors.

As shown in the figure, the CTa current sensor must be positioned on the phase wire coming from the import/export meter so that all the incoming and outgoing power flows can be read.

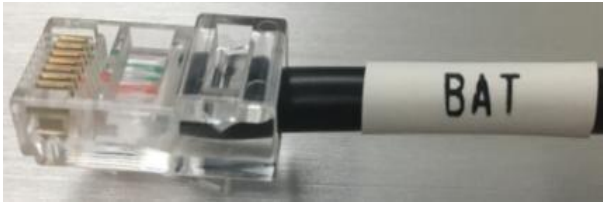
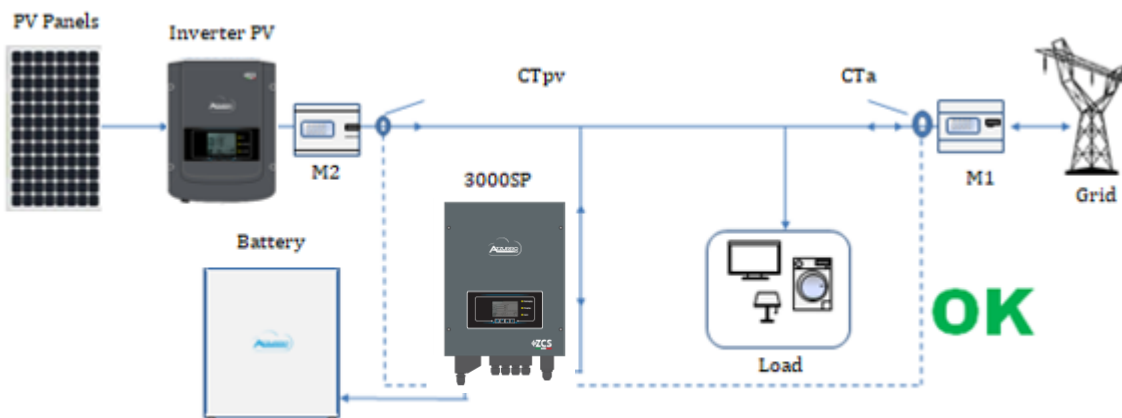

Figure 27 – Correct positioning of the current sensors

The figure below shows an incorrect positioning of the CTa sensor (consumption reading)

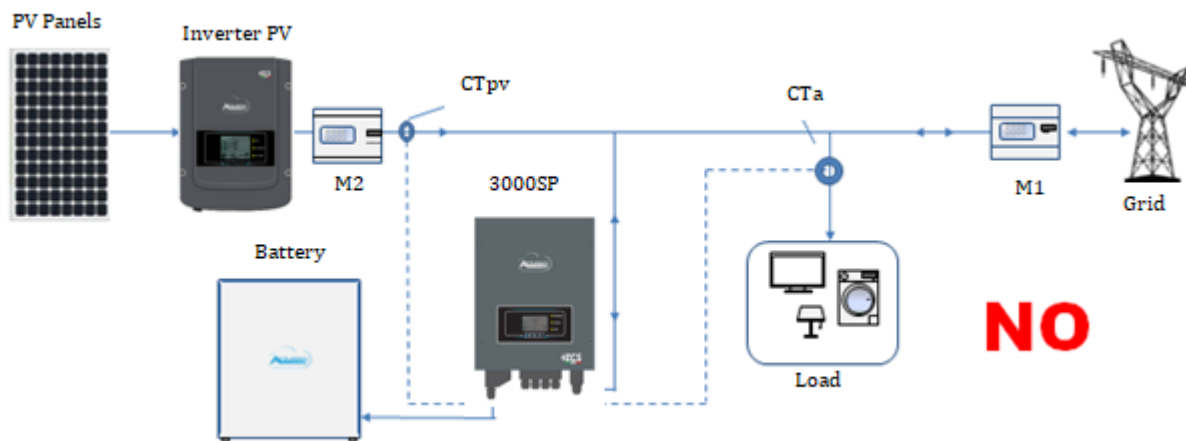

Figure 28 - Incorrect positioning of the current sensors (CTa reading of the utilities only)

In case of multiple phase cables connected in parallel directly under the import/export meter, make sure all the phase cables pass through the CTa sensor, as shown in the figure.

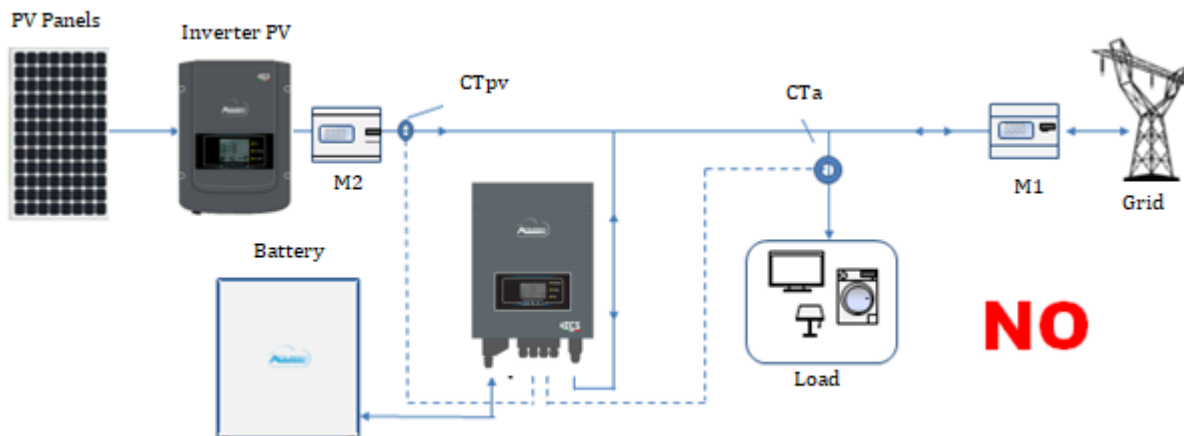

Figure 29 - Correct positioning of the current sensors for a system with two separate lines

4.5. Connecting to the grid

NOTE: If you do not want to configure the EPS (Emergency Power Supply) option, connect the AC power cable only to the GRID port and leave the LOAD port disconnected.

- 1) Unscrew the 4 screws (A) of the right cover with a star screwdriver (figure 30).
- 2) Remove the waterproof cover (B), loosen the cable gland (C), and then remove the stopper (G).
- 3) Route the AC cable (phase, neutral and ground) through the GRID cable gland, then connect the three cables to the corresponding terminal boards of the GRID terminal (Conventionally: BROWN - L, BLUE - N, YELLOW / GREEN - PE).
- 4) Replace the waterproof cover and secure it with the 4 screws; tighten the cable gland.

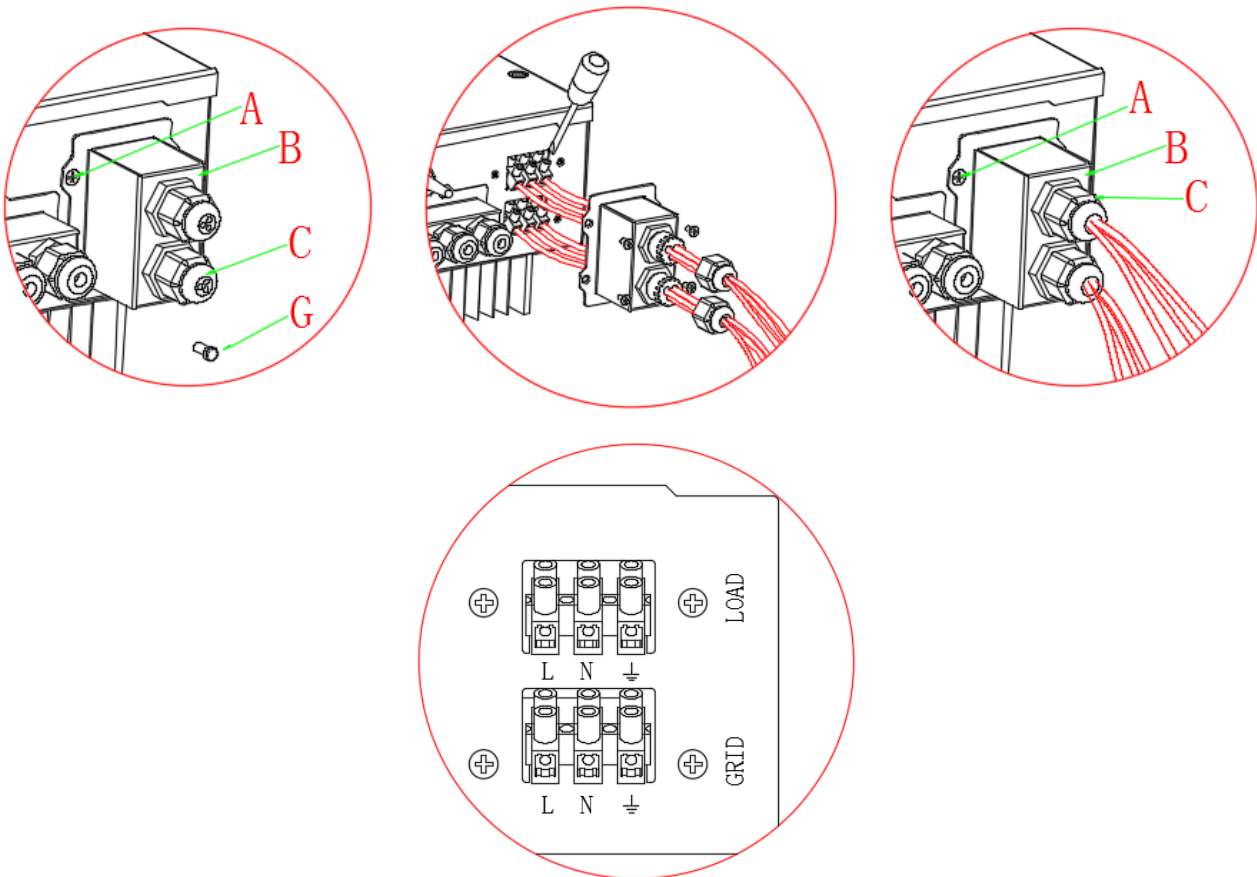

Figure 13 - Connecting the network cable to the GRID terminal block

4.6. Connecting the critical load (EPS function)

In the event of a power failure, if the EPS function is enabled and the batteries are sufficiently charged, the 3000SP inverter will go into EPS mode (emergency power), drawing energy from the battery pack and supplying power to the critical loads via the LOAD port.

The LOAD output must only be used to connect the critical loads; therefore, the user must choose the domestic utilities to be activated in the event of a blackout (e.g. lights, refrigerator, freezer, small household

appliances). Do not connect all the domestic utilities to the LOAD output, as this would compromise duration and operation of the EPS mode; in particular, certain loads, such as the electric motors of some pumps, may require inrush currents much higher than those tolerated by the inverter, causing a power failure.

The EPS function requires an AC power meter (2NC + 2NA double-switchover contactor) to be installed in the system, which is not included in the kit of the storage inverter, and can be purchased separately from a retailer that sells electrical equipment. Install this contactor (see the diagrams and images shown in figures 31 and 32) according to the diagram shown in figure 31, so as to connect the critical loads and electrical grid coming from the import/export meter to the normally closed input, and the critical loads and LOAD input of the storage ' inverter to the normally open input. In this way, the critical loads will normally be powered by the grid, like any other domestic utility, while in the event of a blackout, the meter will switch its input so that the critical loads will be powered directly by the batteries.

The procedure for connecting the LOAD input to the inverter terminal board is identical to that for connecting the GRID port shown in section 4.3, with the only difference being that the phase, neutral and ground cables must be connected to the port marked LOAD.

For more information, please consult the specific procedure available at www.zcsazzurro.com.

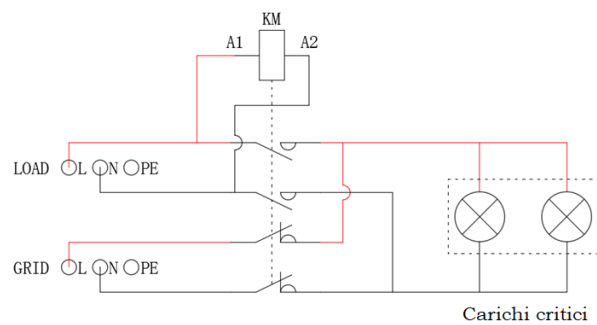

Figure 14 - Diagram of the AC power contactor with 2NC + 2NA double-switchover

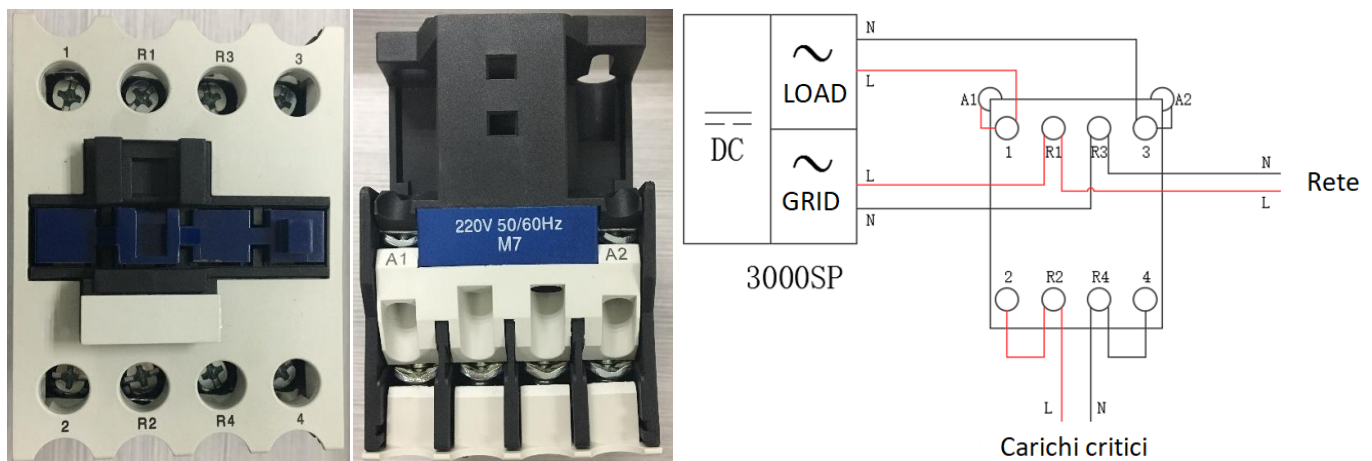

Figure 15 - Front and top view of the power contactor; connecting the contactor inside the system

5. Buttons and indicator lights

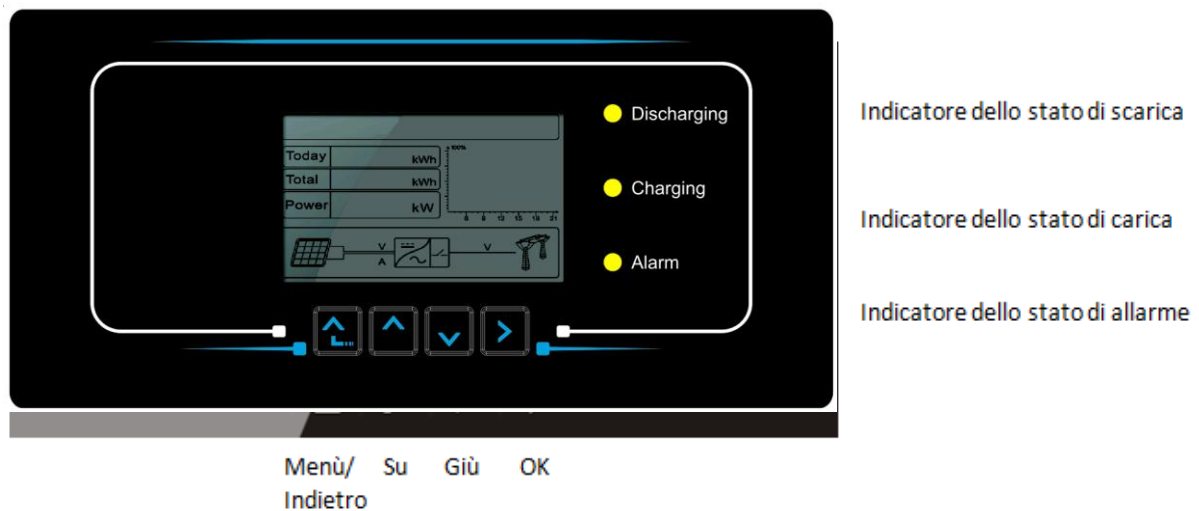

Figure 16 – Buttons and indicator lights of the 3000SP inverter

5.1. Buttons

- Press “Menu/Back” to enter the previous screen or main menu.
- Press “Up” for the upper menu option or to increase the value by 1.
- Press “Down” for the lower menu option or to decrease the value by 1.
- Press “OK” to select the option of the current menu or to move to the next number.

5.2. Indicator lights

- Indicator of the charge status (Green)
 - When the system is in charging control status, the green LED flashes;
 - When the system is charging the battery, the green LED is steady;
 - When the system is in alarm state (temporary or permanent) the green LED is off.
- Indicator of the discharging status (Green)
 - When the system is in discharging control status, the green LED flashes;
 - When the system is discharging the battery, the green LED is steady;
 - When the system is in alarm state (temporary or permanent) the green LED is off.
- Alarm indicator (Red)

- When the system is in alarm state (temporary or permanent) the red LED is steady. It is necessary to check the list of current events.

5.3. Operating status

Operating status	Green discharging light	Green charging light	Red alarm light
Discharge	Steady		
Discharging control	Intermittent		
Charging		Steady	
Charging control		Intermittent	
Standby	Intermittent	Intermittent	
EPS status	Steady	Steady	
Alarm			Steady

6. Operation

6.1. Preliminary checks

Please carry out the following checks before commissioning the inverter.

- 1) The 3000SP inverter must be securely attached to the wall mounting bracket.
- 2) The polarity of the battery cables must be correct and the power cables must be connected securely.
- 3) THE GRID/LOAD cables must be connected securely and correctly to the corresponding terminal block.
- 4) The AC switch must be connected correctly between the inverter's GRID port and the grid. The automatic AC switch must be set to OFF.
- 5) In the case of connection to the EPS, make sure that the AC power contactor is connected correctly.
- 6) For lithium batteries, make sure that the communication cable has been connected correctly.

6.2. Procedure for initial set-up

1. Switch off the photovoltaic system and any other energy generation from renewable sources; this can be done by disconnecting the AC power to the photovoltaic inverter by means of the disconnecting switch installed on the system. Alternatively, the production inverter can be disconnected on the DC side via the switch on board the inverter or the one specifically installed in the system.

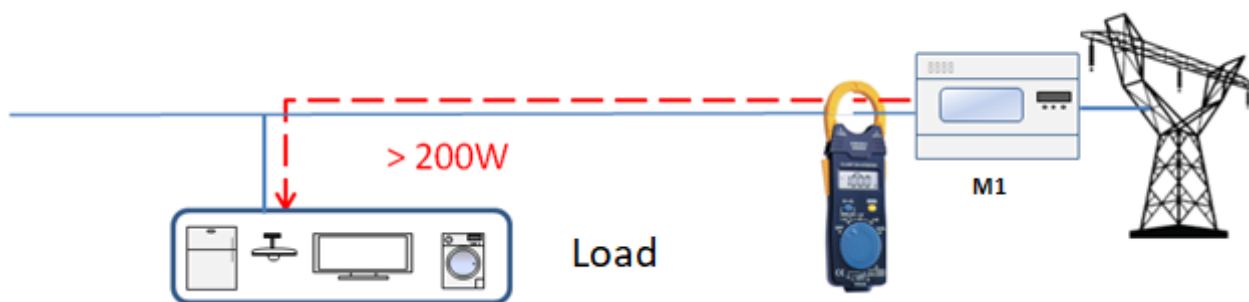

Figure 34 - Checking that the power consumption is above 200W

2. Make sure that the utility has a consumption of at least 200 W. Recommended loads for this operation are hair dryers ($800W < P < 1600W$), electric heaters ($1000W < P < 2000W$) and ovens ($P > 1500W$). Other types of loads, such as washing machines or heat pumps, although characterised by high energy consumption, may take some time to reach this level of absorption after starting.

3. Start the 3000 SP storage inverter

- Supply DC power to the inverter by correctly switching on the batteries:

In the case of Pylontech batteries, set the POWER switch of the battery, or (in the case of multiple units) of all the batteries, to I (ON position), then press the red SW button of the master battery for about one second; at this point the LEDs of all the batteries will light up in sequence, and after a few seconds will turn off, except for the RUN indicating LED.



Figure 35 - Battery status after setting the POWER switch to ON and pressing the SW button

In the case of WeCo batteries, press the RUN button for about one second; after releasing it, wait for the sound inside the battery indicating the closure of the relay. Repeat the operation for all the subsequent batteries in the system.



Figure 36 - View of WeCo battery ON button

- Supply AC power through the dedicated protection switch of the storage inverter. If there is more than one switch protecting the inverter (e.g. a circuit breaker and differential switch), they must all be set to ON to allow the inverter to be connected to the grid.



Figure 37 – Example of AC switch protecting the inverter

b) After carrying out these operations, the display of the inverter will come on.

At the time of start-up, the 3000SP inverter requires the following parameters be set:

1) Date and time	8)*Min. discharge voltage (V)
2) Country	9)*Curr. Discharge Max (A)
3) Battery type	10)*Min. voltage threshold
4)*Battery capacity	11)*Discharge depth
5)*Max charge threshold (V)	12)*End-of-discharge V
6)*Max charge current (A)	13)*End-of-charge V
7)*Overvoltage threshold	

Note: settings 4)* to 13)* will only be present if the DEFAULT option has been selected.

1) Date and time

The date/time format of the System is expressed as “Year-Month-Day-Hours-Minutes-Seconds.” Change the date and time using the “Up” and “Down” keys, press “OK” to confirm and move to the next digit. Once the setting has been completed, the system will automatically move to the next section.

2) Country

Select the code corresponding to the national standard (see table below) which can be set using the “Up” and “Down” keys, press “OK” to move to the next character and confirm. Once the setting has been completed, the system will automatically move to the next section.

Code	Country
00	Germany VDE AR-N4105
01	CEI 0-21 Internal
02	Australia
03	Spain RD1699
04	Turkey
05	Denmark
06	Greece - mainland
07	Netherlands
08	Belgium
09	UK-G59
10	China
11	France

Code	Country
12	Poland
13	Germany BDEW
14	Germany VDE 0126
15	Italy CEI 0-16
16	UK-G83
17	Greece - islands
18	EU EN 50438
19	EU EN 61727
20	Korea
21	Sweden
22	General Europe
23	CEI 0-21 External

Code	Country
24	Cyprus
25	India
26	Philippines
27	New Zealand
28	America
29	Slovakia VSD
30	Slovakia SSE
31	Slovakia ZSD
32	CEI 0-21 Areti
33-49	Reserved

3) **Battery type**

Use the “Up” and “Down” keys to select the type of batteries connected to the system and press “OK” to confirm. If DARFON (1), PYLON (2), SOLTARO (3), ALPHA.ESS (4) or WeCo (if not present, select GENERAL LITHIUM) (5) batteries are used, the setup of the 3000SP storage inverter will be completed; press “OK” to enter into the main interface.

6.3. “FREEZING” current sensors

Starting from firmware version 1.94, the “CT Direction” function is available on the display, which allows faster and more correct installation and configuration of the current sensors.

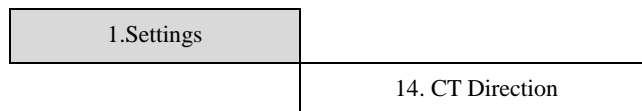

Figure 38 - Settings Menu

To do this, once the inverter has been started, follow the steps below:

1. Press the ESC/Menu key (first key from the left) to enter the main menu.
2. Use the Enter key (fourth key from the left) to enter the “1. Settings” submenu and scroll down with the arrow until the “CT Direction” item is highlighted. Press the Enter key.

Enter the password **0001** using the up and down arrow keys to change the highlighted value by one unit and the ENTER key to move to the next value.

3. A screen similar to the one below will appear.

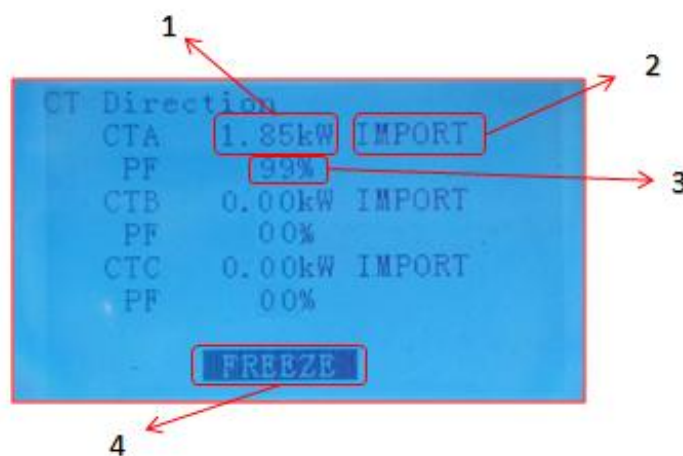

1	Power read by CTa
2	Direction of power flow: <ul style="list-style-type: none"> • IMPORT → from grid to utility • EXPORT → from utility to grid
3	Phase shift between the voltage and current of the phase where the CT is positioned
4	Indicates the status of the current sensors: <ul style="list-style-type: none"> • UNFREEZE → unblocked direction • FREEZE → blocked direction

Figure 39 – Screen relating to the CT Direction submenu

The three lines show the information relating to the CT inputs, the reading of the detected power, the direction of this and the Power Factor; for example, the figure shows a CTa sensor reading equal to 1.85 kW being imported from the grid towards the utility; in this case, the Power Factor indicates the phase shift of the current measured with respect to the voltage.

At power-up (i.e. during the initial waiting time), make sure that there is more than 200W of power on the CTa three-phase in IMPORT conditions in order to correctly direct the probe with a Power Factor value of more than 90%.

4. When the appropriate start-up conditions (imported power > 200 W and PV > 90% 90% on all phases) have been met, it will be possible to “freeze” this situation so that it does not have to be repeated on future system start-ups.
 - a. Press the second key ↑ to display the FREEZE message at the bottom
 - b. Press ENTER to confirm.

This activates the FREEZE option, which blocks the direction of the sensor, making subsequent machine start-ups easier.

In case of error during the start-up procedure and incorrect direction of the sensor, it is possible to cancel the FREEZE operation by simply entering into the CT direction menu and changing the FREEZE option to UNFREEZE, using the up arrow key and confirming with the ENTER key.

- Exit the menu with the ESC/MENU key to return to the main interface.

The initial start-up procedure is now complete and does not have to be repeated when the machine is restarted in the future.

- At this point, the photovoltaic system can be switched on for production.



Figure 40 – Switching on the photovoltaic inverter

6.4. Menu

From the main screen, press “Menu/Back” to enter the main menu. The main menu contains five different options:

Main menu	
1. Settings	1. Enter Setting
2. Event list	2. Event List
3. System Info	3. System Info
4. Software Update	4. Software Update
5. Energy statistics	5. Energy Statistics

6.4.1.Settings

1.Settings	1.Battery Parameters	9.EPS Mode
	2.Delete Energy Data	10.Logic interface control
	3.Clear events	11.Autotest
	4.Set Country	12.Working Mode
	5.Commun.Address Select.	13.CTpV Scale Factor
	6.Enable Country Change	14. CT Direction
	7.Lingua	13.Set parameters Safety
	8.Date and time	

1. Battery parameters

1.Battery Parameters	1.Battery Type	7.Max. discharge current (A)
	2*.Battery capacity	8*. Min. voltage threshold
	3.Depth of discharge	9.Min discharge voltage (V)
	4.Max charge current (A)	10*.End-of-discharge V (V)
	5.Over-voltage threshold	11*.End-of-charge V (V)
	6.Max charging threshold (V)	12.Salvare

Note: settings 2*/8*/10*/11* are only accessible for DEFAULT batteries.

Press the “Menu/Back” button to enter the main menu, then press the “OK” button to enter the menu “1. Settings”, and then “OK.” Now press the “OK” button to enter the menu “1. Battery Parameters.” The

display will show “Enter PWD!”, press OK to enter the password (use “Up” and “Down” to choose the number and “OK” to move to the next digit):

- for standard settings, enter “0001”
- for advanced settings (recommended for installers), enter “0715”

If the display shows “Incorrect, try again!” press the “Menu/Back” button and enter the password again.

After entering the password, select the type of battery used in the system:

1) Battery type

Scroll up and down using the “Up” and “Down” keys to select the type of battery used. Press “OK” to confirm the setting and wait for “OK” to appear on the display. If you are using Pylontech lithium batteries supplied with the storage inverter, select the option “PYLON.” If you are using WeCo lithium batteries, select the “WeCo” or “GENERAL LITHIUM” option.

A menu will now open for setting the following options:

2) Battery capacity (only for DEFAULT batteries)

Select “2. Battery Capacity” and press “OK” to set the capacity of the battery or the battery system expressed in Ah. Press the “Up” and “Down” keys to change the value of the capacity. Press “OK” to move to the next digit and then confirm the setting; wait for “OK” to appear on the display. When setting this parameter, refer to the relative datasheet of the battery used.

3) Depth of discharge

Depth of discharge
50%
EPS depth of discharge
80%

Select “3. Depth of discharge” and press “OK” to enter the menu for setting the depth of discharge. Press the “Up” and “Down” keys to change the depth of discharge in both normal operating mode and in EPS mode depending on the type of batteries used. Press “OK” to move to the next digit and then confirm the setting; wait for “OK” to appear on the display.

The depth of discharge indicates the percentage of the battery level actually used; for example, a depth of 80% will allow cycles between 20% and 100% of the battery charge level.

A different depth of discharge value can also be set for standard operation and EPS operation. For example, you can set a DOD equal to 50% and an EPS DOD equal to 80%. In this case, when the grid connection is present, the 3000SP storage inverter will not draw energy from the batteries if the charge level is below 50%. In the event of a power failure, the 3000SP storage inverter will operate in EPS mode (if this was previously set) and will remain in discharge mode until the battery charge level

drops to 20%.

4) Maximum charge current (A)

Select “4. Maximum charge current (A)” and press “OK” to enter the menu for setting the maximum charge current. Press the “Up” and “Down” keys to change the value of the maximum charge current. Press “OK” to move to the next digit and then confirm the setting; wait for “OK” to appear on the display.

When setting this parameter for Pylontech batteries, refer to the table in section 6.2; for different battery models, refer to the relative datasheet.

5) Overvoltage threshold

Select “5. Overvoltage threshold” and press “OK” to enter the menu for setting the overvoltage protection voltage. Press the “Up” and “Down” keys to change the value of the overvoltage protection voltage. Press “OK” to move to the next digit and then confirm the setting; wait for “OK” to appear on the display.

When setting this parameter for Pylontech batteries, refer to the table in section 6.2; for different battery models, refer to the relative datasheet.

6) Max charge threshold (V)

Select “6. Min Discharge Voltage (V)” and press “OK” to enter the menu for setting the minimum discharge voltage. Press the “Up” and “Down” keys to change the value of the minimum discharge voltage. Press “OK” to move to the next digit and then confirm the setting; wait for “OK” to appear on the display.

When setting this parameter for Pylontech batteries, refer to the table in section 6.2; for different battery models, refer to the relative datasheet.

7) Maximum discharge current (A)

Select “7. Max discharge current (A)” and press “OK” to enter the menu for setting the maximum discharge current. Press the “Up” and “Down” keys to change the value of the maximum discharge current. Press “OK” to move to the next digit and then confirm the setting; wait for “OK” to appear on the display.

When setting this parameter for Pylontech batteries, refer to the table in section 6.2; for different battery models, refer to the relative datasheet.

8) Minimum voltage threshold (only for DEFAULT batteries)

Select “8. Min voltage threshold” and press “OK” to enter the menu for setting the protection voltage for low voltage. Press the “Up” and “Down” keys to change the value of the protection voltage for low voltage. Press “OK” to move to the next digit and then confirm the setting; wait for “OK” to appear on the display.

When setting this parameter, refer to the relative datasheet of the battery used.

9) Minimum discharge voltage

Select “9. Min Discharge Voltage (V)” and press “OK” to enter the menu for setting the minimum discharge voltage. Press the “Up” and “Down” keys to change the value of the minimum discharge voltage. Press “OK” to move to the next digit and then confirm the setting; wait for “OK” to appear on the display.

When setting this parameter for Pylontech batteries, refer to the table in section 6.2; for different battery models, refer to the relative datasheet.

10) End-of-discharge voltage (only for DEFAULT batteries)

Select “11. End-of-discharge V” and press “OK” to enter the menu for setting the end-of-discharge voltage. Press the “Up” and “Down” keys to change the value. Press “OK” to move to the next digit and then confirm the setting; wait for “OK” to appear on the display.

When setting this parameter, refer to the relative datasheet of the battery used.

Note: This setting is very important for lead-acid batteries, while it is not so important for lithium batteries with BMS.

11) End-of-charge Voltage (only for DEFAULT batteries)

Select “11. End-of-charge V” and press “OK” to enter the menu for setting the end-of-charge voltage. Press the “Up” and “Down” keys to change the value. Press “OK” to move to the next digit and then confirm the setting; wait for “OK” to appear on the display.

When setting this parameter, refer to the relative datasheet of the battery used.

Note: This setting is very important for lead-acid batteries, while it is not so important for lithium batteries with BMS.

12) Save

Select “Save” and press “OK” to save all the settings.

2. Delete Energy Data

Select “2. Delete Energy Data” and press “OK.” The display will show “Enter PWD!” Press “OK” to enter the password “0001” using the “Up” and “Down” keys to select the number and “OK” to move to the next digit. If the display shows “Incorrect, try again!” press the “Menu/Back” key and enter the password again. When the correct password is entered, the menu for resetting the statistics will open and the data relating to the energy produced and consumed will be automatically deleted in the appropriate section of the main menu.

3. Clear Events

Select “3. Clear Events” and press the “OK” key twice to completely clear the events recorded; this will clear all the errors recorded in the memory of the inverter. Wait for “OK” to appear on the display, then press the “Menu/Back” key to return to the previous menu.

4. Set Country

Select “4. Set Country” and press “OK” to enter the menu for setting the national grid regulations. Press “OK” and if “Setting Disabled” appears on the display, go to item “6. Enable Country Change” to enable this function. Once the function has been enabled, repeat the steps described above and set the code relating to the desired national regulations. Press the “OK” key and wait for “OK” to appear display.

For more information and to know the country regulations on board the inverter, refer to the relevant section.

5. Select communication address

Select “5. Select Comm. Address” and press “OK” to enter the menu for selecting the communication address. Press the “Up” and “Down” keys to change the first digit, press OK to go to the next one, and confirm. After setting the address, press “OK.”

The communication address indicates the address with which the inverter sends its data to the monitoring server. Address 01 is used for single inverters; if you want to extend the monitoring to multiple 3000SP inverters, progressive communication addresses will be used.

Note: make sure that the address entered is never 00.

6. Enable Country Change

Select “6. Enable Country Change” and press “OK”. The display will show “Enter PWD!”, press “OK” to enter the password. Enter the password “0001” using the “Up” and “Down” keys to select the number and “OK” to move to the next one. If the display shows “Incorrect, try again!” press the “Menu/Back” key and enter the password again.

This operation must be carried out to change the Country Code if it has not been changed during the last 24 hours of operation.

7. Language

Select “7. Language” and press “OK” to enter the menu for selecting the language. Select the language using the “Up” and “Down” keys; then press “OK” to confirm.

A faster way to change the menu language is to press the “Menu/Back” key and “OK” key at the same time. In firmware version V1.90, the languages available are Chinese, English, Italian, French, German, Slovak and Ukrainian; future firmware updates may add new languages.

8. Date and time

Select “8. Date and time” and press “OK” to enter the menu for setting the date/time. Set the date and time using the “Up” and “Down” keys, then press “OK” to move to the next digit and confirm. The date and time are expressed in the format: 20YY – MM - DD HH:MM:SS.

The date and time are shown at the bottom left of the main interface.

The correct setting of this menu is fundamentally important if you want to set the working mode %Charge (for more information, see section 12 of this chapter).

9. EPS Mode (Emergency Power Supply)

Select “9. Set EPS mode” and press “OK” to enter the menu for setting the EPS mode. The following screen appears on the display.

9. Set EPS mode	1. EPS setting	1. Enable EPS
		Disable EPS
	2. Set EPS start-up time	***s

Select the menu “1. EPS setting” and press “OK” to enter; use the “Up” and “Down” keys to select between “Enable EPS” and “Disable EPS”, then press “OK” to confirm.

If the Enable EPS option is set, select the menu “2. Set EPS start-up time” and press “OK”; use the “Up” and “Down” keys to change the digit and “OK” to move to the next one. When the AC voltage is interrupted, the EPS mode will enter into operation after the set time. This value can be set between 1 and 999 seconds.

For more information on EPS mode, refer to the appropriate procedure.

10. DRMs0 Control (only for the Australian market)

Select “10. DRMs0 Control” and press “OK.” The display will show “Enter PWD!” Press “OK” to enter the password “0001” and use the “Up” and “Down” keys to select the digit and “OK” to move to the next digit. If the display shows “Incorrect, try again!” press the “Menu/Back” key and enter the password again.

When the correct password has been entered, the menu for setting the DRMs0 Control will appear. Select “1. Enable DRMs0” or “2. Disable DRMs0” if you want to enable or disable this function. Press “OK” and wait for “OK” to appear on the display.

Note: this setting is only used in countries where the Australian standards are in force; in all other situations, it should be ignored.

11. Self-test

Select “11. Self-test” and press “OK” to enter the self-test interface.

Note: this setting is only used in Italy and is therefore visible only if country code 01 or 15 has been set.

11.Self-test	
	1.Fast Self-test
	2.STD Self-test
	3.Set PF time
	3.Set QV time
	5.Enable 81.S1

1) Fast self-test

Select “1. Fast Self-Test”, then press “OK” to start the fast self-test, which will be performed automatically and will take about 15 minutes. The following screens will be shown on the display.

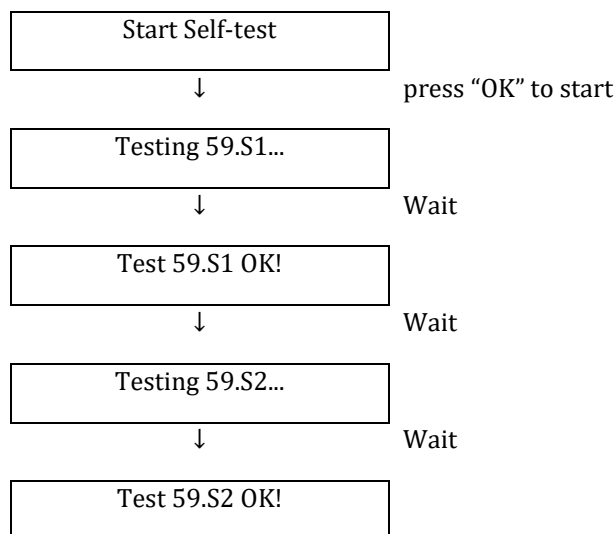

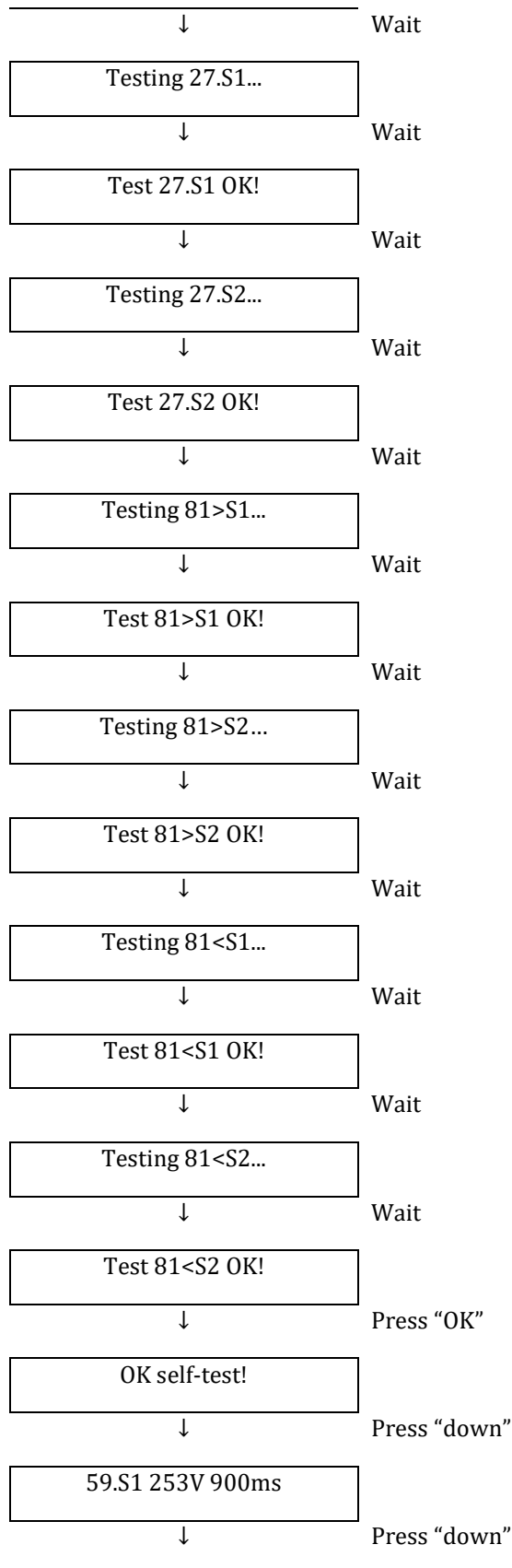

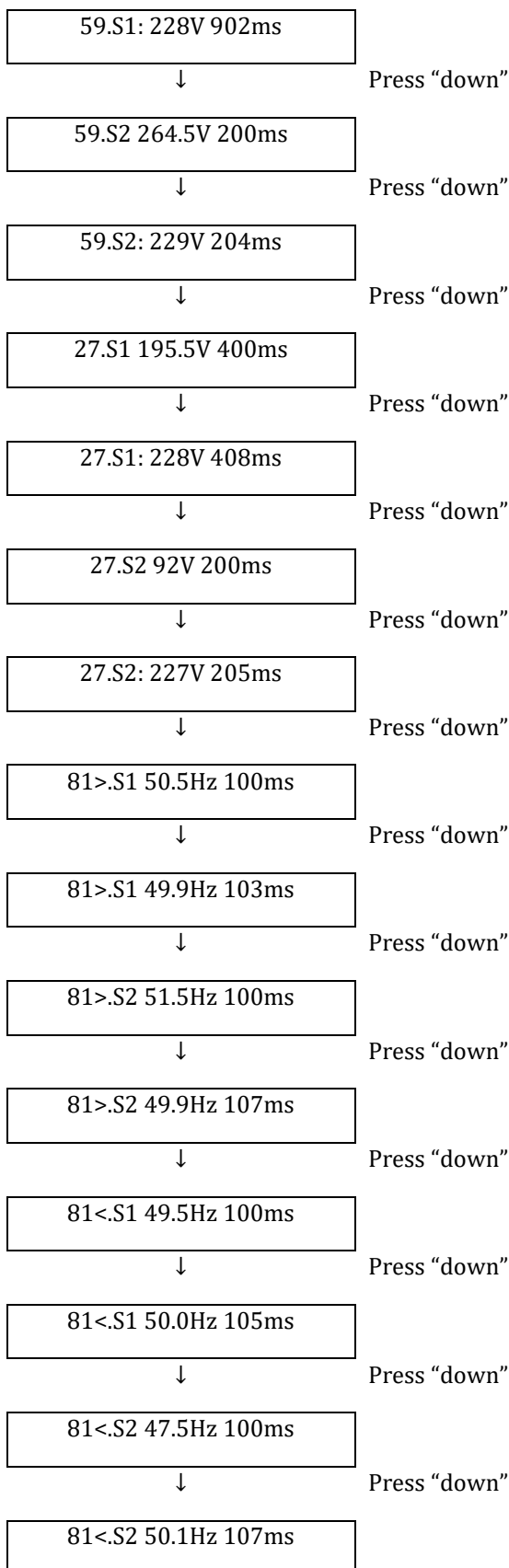

2) STD Self-test

Select “2. STD Self-test” and press “OK” to start the standard self-test. The test procedure is the same as the fast self-test with the difference that the waiting times are longer (about 45 minutes) due to the 300-second wait between one test and the next.

3) Set PF time

Select “3. Set PF time” and press “OK” to enter the menu for setting this parameter. The display will show the following:

Set : *.*** s

*.*** represents the time to be set in seconds. Use the “Up” and “Down” keys to set the desired value. Press “OK” and wait for “OK” to appear on the display.

This function is required by various standards for grid-connected inverters, and allows the active power to be changed based on the grid frequency according to the requirements of the local standards.

This option allows setting the delay time (expressed in seconds) with which the change in P power occurs.

4) Set QV time

Select “4. Set QV time” and press “OK” to enter the menu for setting this parameter. The display will show the following:

Set : ** s

** represents the time to be set in seconds. Use the “Up” and “Down” keys to set the desired value. Press “OK” and wait for “OK” to appear on the display.

This function is required by various standards for grid-connected inverters, and allows the reactive power to be changed based on the grid frequency according to the requirements of the local standards.

This option allows setting the delay time (expressed in seconds) with which the change in Q power occurs.

5) Enable 81.S1

Select “5. Enable 81.S1” and press “OK.” Select “1. Enable 81.S1” or “2. Disable 81.S1” if you want to enable or disable this function. Press “OK” and wait for “OK” to appear on the display.

This function enables the restrictive frequency thresholds required in some cases by local regulations.

12. Working mode

Select “12. Working Mode” and press “OK” to enter the interface for setting the working mode.

12.Working Mode	
	1.Set Auto Mode
	2.Set %Charge Mode
	3.Set Hourly Mode
	4.Set Passive Mode

1) Set Auto Mode

Select “1. Set Auto Mode” and press “OK” to set automatic mode. In this mode, the device will automatically establish the start and end of the charging to ensure that the energy stored in the battery and the battery charge state are optimal. Below is an example of how the system operates in automatic mode.

The 3000SP will remain in Standby as long as the energy produced by the photovoltaic system is less than that requested by the loads (or the difference is < 100W).

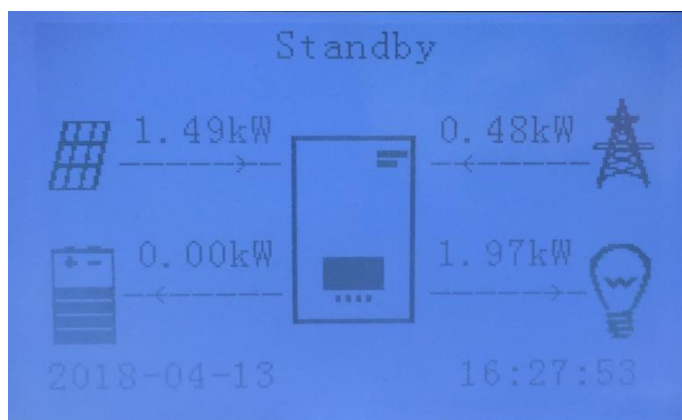

When the energy from the photovoltaic system is greater than that requested by the loads, the 3000SP will give priority to charging the battery with the excess energy.

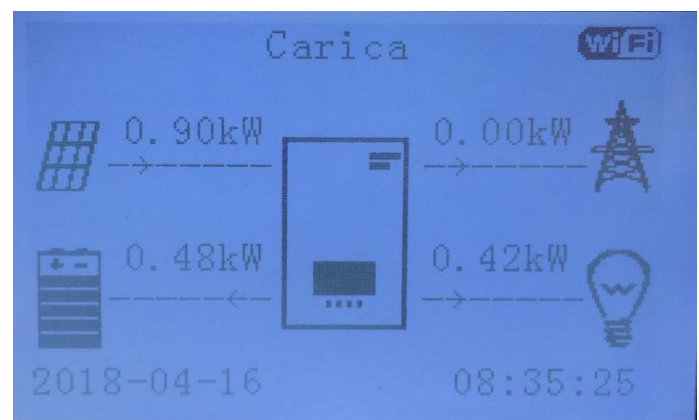

When the battery is fully charged (or when the charging power is limited), the excess energy will be exported to the grid.

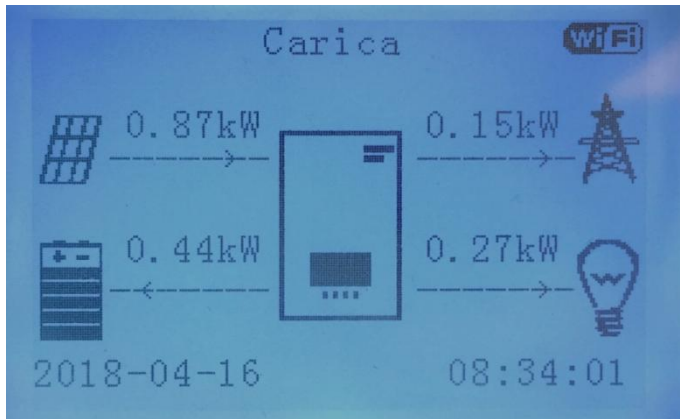

When the energy from the photovoltaic system is once again lower than that requested by the loads, the system will give priority to the energy stored in the battery.

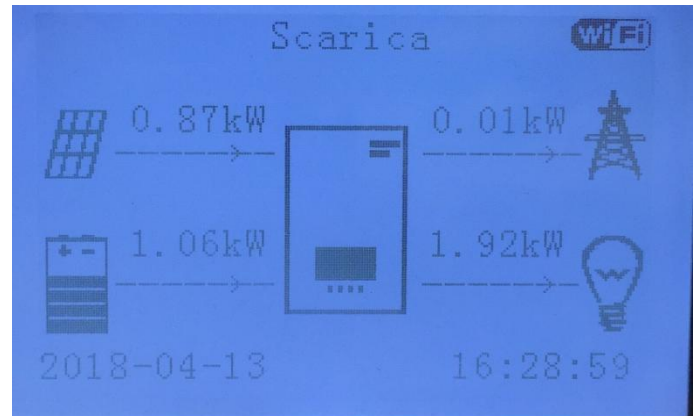

When the sum of the energy produced by the photovoltaic system and supplied by the battery is less than that required by the loads, the missing energy will be taken from the grid.

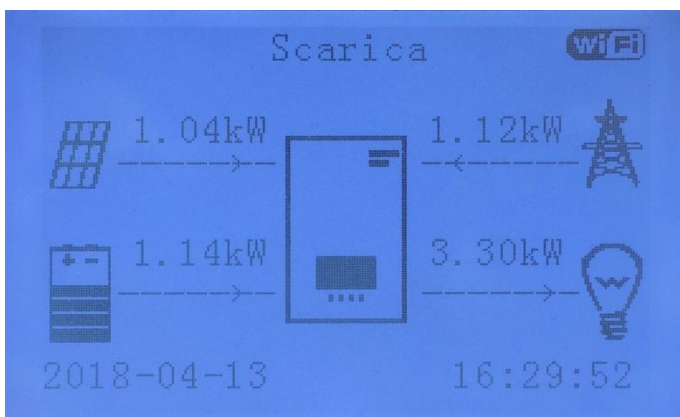

Press the “Down” key from the main menu to access the instantaneous information on the operation of the 3000SP.

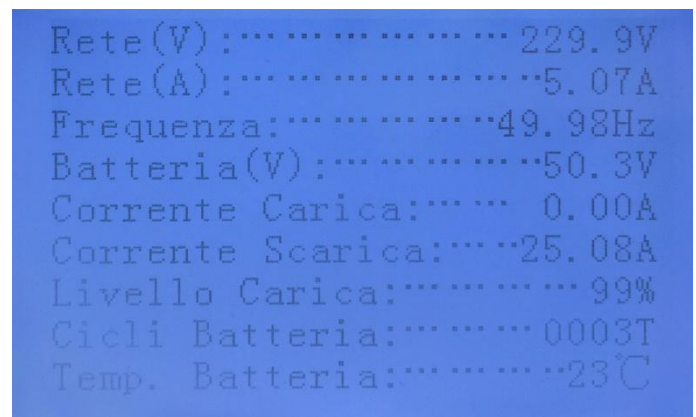

Below are the instantaneous information and values that can be seen by pressing the “Down” key from the main interface.

Grid (V)	Indicates the voltage of the grid in Volts
Grid (A)	Indicates the current exchanged with the grid in Ampere (the symbol - in front of the figure indicates a transfer of power to the grid)
Frequency	Indicates the frequency of the grid expressed in Hertz

Battery (V)	Indicates the voltage of the battery pack expressed in Volts
Charge current	Indicates the current at which the battery pack is currently being charged
Discharge current	Indicates the current at which the battery pack is currently being discharged
Charge level	Indicates the charge percentage of the battery pack
Battery Cycles	Indicates the number of complete charging and discharging cycles performed by the battery pack
Battery Temp.	Indicates the temperature measured on the cells of the battery pack

2) Set %Charge Mode

Select “2. Set %Charge Mode” and press “OK” to enter the menu for setting this %Charge. In this mode, the user can select one or more time intervals (both hourly and daily) during which the battery will be forced to charge, also drawing power from the grid if the power supplied by the photovoltaic system is not sufficient. The maximum charge level (SOC) and the power with which the battery will be recharged can also be set.

Set %Charge Mode			
Rules. 0: Enable			
From	To	DOD	Charge
21h00m -	06h00m	090%	1000W
Effective date			
Dec. 22 - Mar. 21			
Weekdays			
Mon. Tue. Wed. Thu. Fri. Sat. Sun.			

3) Set Hourly Mode

Select “3. Set Hourly Mode”, then press “OK” to enter the interface of the set charge/discharge mode. In this mode, it is possible to select a forced charging and discharging period for the battery, as well as the power to be used for performing these operations.

Note: this mode is normally used to check that the 3000SP inverter is correctly charged and discharged. Therefore, this mode is not recommended during normal operation of the system. Below is an example of the screen.

Start of charge	22 h 00 m
End of charge	05 h 00 m
Charge Power	2000 W
Start of Discharge	14 h 00 m
End of Discharge	16 h 00 m
Discharge Power	2500 W

4) Set Passive Mode

Select “4. Set Passive Mode”, then press “OK”.

For more detailed information, ask Technical Support for a copy of the communication protocol in passive mode.

13. Setting Safety Parameters

Select “13. Set Safety Param.” and press “OK”; the “enter password” screen will be displayed. Enter the password “0001” using the “Up” and “Down” keys to select the digit and “OK” to move to the next digit, and confirm.

This option is used to set various initialisation, voltage and frequency parameters in order to adapt the inverter to installation sites where thresholds different from those required by the national standards are required.

To change the parameters and the voltage and frequency thresholds, for example, send an email to Technical Support requesting the appropriate text files. Once you receive the .TXT files, copy them in the main directory of the SD card (for a more detailed description on how to extract the SD card, refer to chapter 6.4.4); once the SD card has been inserted back into its slot, press “Up” or “Down” to select from the menu in question:

1. Set Start Param.
2. Set safety V
3. Set safety Hz

press “OK” and wait for “OK” to appear on the display.

Note: for more information and to request the firmware update files, please contact the ZCS Azzurro Technical Support on the toll free number [800 727464](tel:800727464) (available only in Italy).

6.4.2.Event List

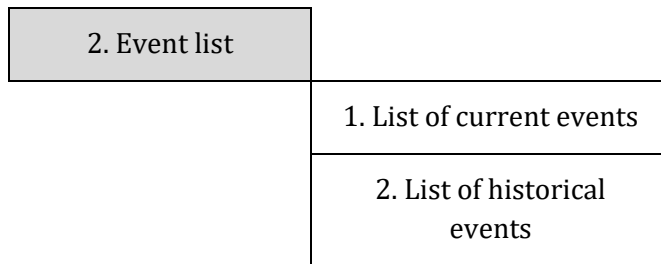

To access the list of events, which contains information on the inverter errors, it is necessary to go back to the main interface and press the “Menu/Back” key, scroll down with the arrow to point “2. Event List” and enter with the “OK” key. At this point, you will be able to access the list of current events and the list of all the historical events.

1) List of current events

Select “1. List of current events” and press “OK” to access the information on the errors currently present in the inverter; in particular, you will be able to view the number of errors, the identification code, and date/time at which they occurred. An example of the screen is shown below.

ID events	Intervention time
1. ID02	2018-03-16 09:56
2. ID03	2018-03-16 09:56

2) List of historical events

Select “2. List of historical events” and press “OK” to access the information on the history of errors in the memory; in particular, you will be able to view the number of errors, the identification code, and date/time at which they occurred. Use the “Up” and “Down” keys to switch from one screen to another in order to view all the errors. An example of the screen is shown below.

ID events	Intervention time
1. ID02	2018-03-16 09:56
2. ID03	2018-03-16 09:56
3. ID85	2018-03-05 21.45
4. ID52	2018-02-24 08.12
5. ID98	2018-02-15 17.34

6.4.3. System Information

To enter the screen containing general information on the system, go back to the main menu and press the “Menu/Back” key, scroll down with the arrow to item “3. System Info” and enter with the “OK” key. You will then be able to enter the menu with information on the inverter and batteries. Scroll with the “Up” and “Down” keys to view all the screens. An example of the screen is shown in the table below.

Note: the number and type of information may vary depending on the type of battery set.

3. System Info			
	System info (1)	Serial number	Serial number of the machine
		Software version	Software version installed
		Hardware version	Hardware version
		RS485 address	Address of Wi-Fi communication
	System info (2)	Country	Country code for legislation in force
		Service Code	Firmware version installed
		EPS	Information on EPS mode
		Working mode	Information on working mode
System info (3)	DRMs0 Control	Information on DRMs0 mode	
		Set PF time	Response delay in frequency
		Set QV time	Response delay in voltage
		Power Factor	Power factor value
Battery parameters (1)	Battery type	Battery model set	
		Battery capacity	Battery capacity in Ah
		Depth of Discharge	Percentage of battery discharge
		Max charge current (A)	Maximum charge current in A
Battery parameters (2)	Overvoltage threshold	Maximum voltage value (protection)	

	Max. charge threshold (V)	Value of maximum voltage (charge)
	Max. discharge current (A)	Maximum discharge current in A
	Min. discharge voltage (V)	Minimum voltage value (protection)
Battery parameters (3)	Min. voltage threshold	Minimum voltage value (discharge)
	End-of-discharge V	Voltage with batteries charged to 0%
	End-of-charge V	Voltage with batteries charged to 100%

6.4.4. Software Update

Before updating the software from the display, send an ZCS Azzurro Technical Support requesting the files for updating the 3000SP inverter firmware. Proceed as follows:

1. Switch off the ZCS 3000SP inverter by disconnecting the AC power and turning off the batteries. If Pylontech batteries are used, set the switches of each battery in the pack to 0. If WeCo batteries are used, press the POWER button for 5 seconds until the RUN light switches off.
2. Remove the central cover at the bottom of the inverter by unscrewing the four star screws, making sure to loosen the four cable glands (as shown in the figure).

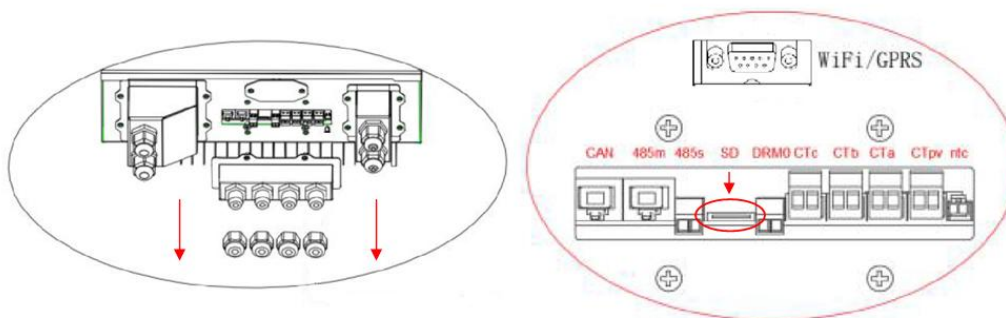

3. Extract the microSD card from its slot (shown in the figure above) by pressing lightly on the card and pulling it out of the inverter. Then insert it into the PC using the appropriate adapter.
4. Open the SD card drive and create a new folder with the name **ES3000firmware**, making sure to match the lowercase and uppercase letters as indicated and checking that there are no spaces. Now copy the files attached to the email into the **ES3000firmware** folder.
5. Extract the SD CARD from the PC using the “safely remove hardware” process.

6. Insert the SD card in the appropriate slot of the inverter.
7. If Pylontech batteries have been installed, start the system by first positioning the switches of all the batteries on "I" and then pressing the red SW button on the master battery (i.e. the battery connected to the storage system via the communication cable).
If WeCo batteries have been installed, press the POWER button for one second, making sure that the green RUN light turns on.
8. Power up the storage system via the circuit breaker installed.
9. When the display turns on (approximately 2-3 seconds after the AC circuit breaker has been closed), disconnect the AC power to the ZCS storage system again.
10. From the display, press the "Menu/Back" key (first from the left) to enter the menu, and press the "OK" key (fourth from the left) to enter the item "5. Software Update". Enter the password **0715** and press "OK" again to start the update.
11. The update process will take about 3 minutes and will run automatically.
12. Check that the inverter completes the update correctly and that it is in the final FAULT condition (normal since the inverter is disconnected from the AC grid). If the message "Communication Failed" appears, switch off the inverter and repeat the procedure starting from step 7.
13. Once the update has been completed successfully, it is necessary to change the country code: enter the Settings menu by pressing the "Menu/Back" key, then scroll down to the fourth item "Set Country" and enter the country code 22.

Note: if the inverter has been running for more than 24 hours, enable the function by entering the "Enable Country Change" menu, which corresponds to item 6 of the Settings menu. Enter the password **0001**.
14. Switch off the batteries and inverter again by setting the battery switches to 0, then wait a few minutes.
15. Restart the inverter by first supplying DC power from the batteries and then AC power from the circuit breaker installed.
16. Disconnect the AC power supply, and then enter the "set country" menu again. Set the country code according to the appropriate grid standard (e.g. for Italy: CEI-021 INT, CEI-021 EXT, CEI-016).
17. Switch off the system and restart it after waiting a few minutes, as indicated in step 15.
18. Enter into the Settings menu and then the Battery Parameters submenu, enter the password **0715**. Select the type of batteries (PYLON if PYLONTECH batteries are used, or WeCo or GENERAL LITHIUM if WeCo batteries are used) and set the parameters according to the type and number of batteries installed.

Note: it is necessary to set all the values requested, even if they do not change from the default

values. Once completed, Save.

19. The update procedure is now completed and the system must now be restarted correctly by following the initial start-up procedure described in the relevant section.

Note: if the message “DSP1 Update Failed” or “DSP2 Updated Failed” appear during the update, the firmware update has not been successful. Therefore, it is necessary to switch off the system by first lowering the AC switch and then the switches located on the batteries. Wait 3 minutes and follow the above steps again, starting from point 7.

Note: for more information and to request the firmware update files, please contact the ZCS Azzurro Technical Support on the toll free number [800 727464](tel:800727464) (only in Italy).

6.4.5. Energy Statistics (Energy statistic)

To enter the screen containing the energy statistics of the system, go back to the main interface and press the “Menu/Back” key, scroll down with the arrow to point “5. Energy Statistics” and enter with the “OK” key. This interface shows the data relating to the generation of the photovoltaic system and to the consumption of the utility in a certain time interval. Press the “Up” and “Down” keys to scroll through the different time periods: day, week, month, year and life cycle.

An example of the daily statistics screen is shown below.

5. Energy Statistics			
Today			
PV prod.	10.00KWh		
SelfCon	8.00KWh	80%	
Export	2.00KWh	20%	
Consump.			
SelfCon	7.00KWh	21.87%	
Amount	25.00KWh	78.13%	

7. Connections in three-phase mode

The 3000SP storage inverter is a single-phase inverter, but it can be installed on a three-phase system by feeding and withdrawing power on a single-phase, with the aim of zeroing the vector sum of the powers of each phase ready by the import/export meter. In order to use this mode, it is necessary to have PV production generated by a three-phase inverter.

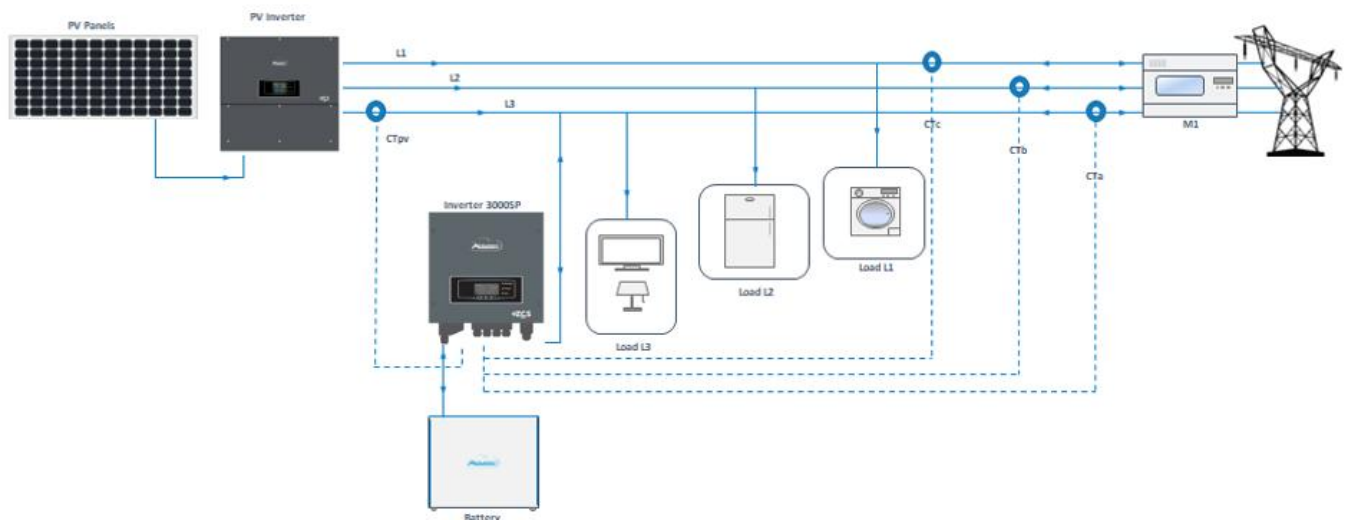

Figure 41 – Installation of a 3000SP storage inverter on a three-phase system

In the example shown in Figure 41 - Power flows in a 3000SP storage inverter on a three-phase system, the inverter is installed on phase L3 (washing machine), however, the loads installed on the other two phases (lighting and refrigerator) are also taken into account for its automatic operation, and the balance of power flows takes into consideration the entire photovoltaic production and the absorption of all the loads.

For example, if we assume a three-phase system and a photovoltaic production of 6 kW, and take into account the values shown in the figure, we can say that:

- In phase L1, the loads are absent and the power produced is fed into the grid.
- In phase L2, 5 kW are requested, of which 2 kW are supplied by the photovoltaic system and 2 kW are taken from the grid.
- In phase L3, where the storage inverter is installed, the loads absorb a power of 4 kW; this request is met partly by the photovoltaic production (2 kW) and partly by the batteries (3 kW). In any case, instead of only delivering the 2 kW needed to meet the requirements of the loads on the phase, an additional 1 kW is also delivered, which is then sold to the grid to balance the greater absorption on phase L2.

7.1. CT / Battery Communication / RS485 Connections

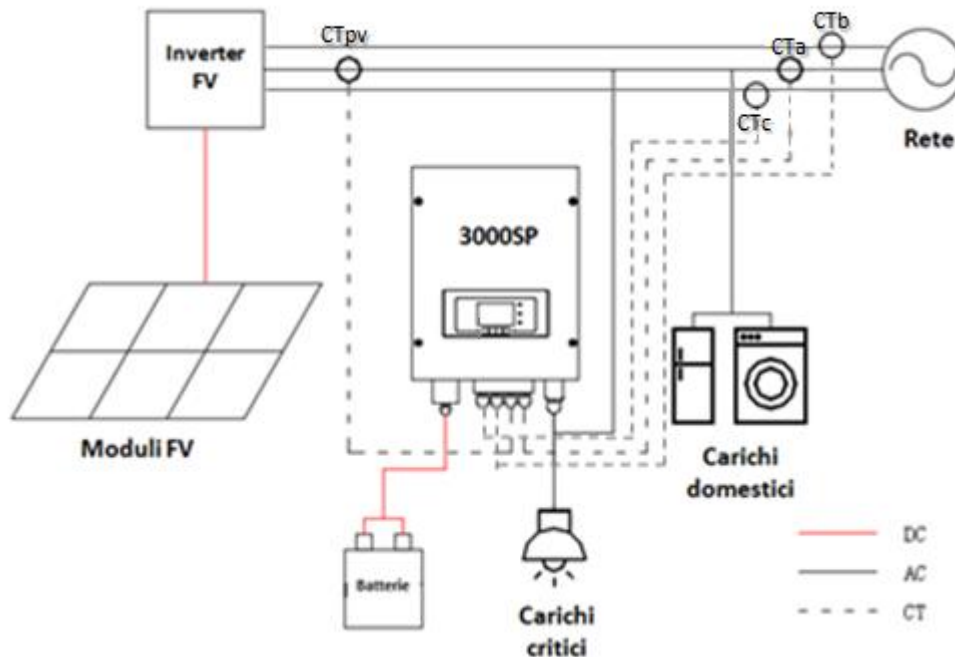

Figure 43 - Wiring diagram of the 3000SP storage inverter inside a system powered by renewable energy

- 9) Correctly position the four current sensors (CT):
- the CTa for measuring the energy exchanged with the grid must be positioned at the output of the exchange meter (utility side) on the same phase where the storage unit has been installed, and must include all the phase cables entering or leaving the meter. The CTa will therefore measure both the energy fed into the grid by the photovoltaic system and the energy withdrawn to meet the requirement of the utilities on its phase.
 - the CTb and CTc, each positioned on the other two phases, must include all phase cables entering or leaving the meter. The CTb and CTc will measure both the energy fed into the grid by the photovoltaic system and the energy withdrawn to meet the requirement of the utilities, each on its own phase.
 - The CTpv for measuring the photovoltaic production must be positioned on the phase cable exiting the photovoltaic inverter (utility side) or from the production meter, and will only measure the energy generated by the photovoltaic inverter. The CTpv must be positioned on the phase where the 3000SP inverter is installed.

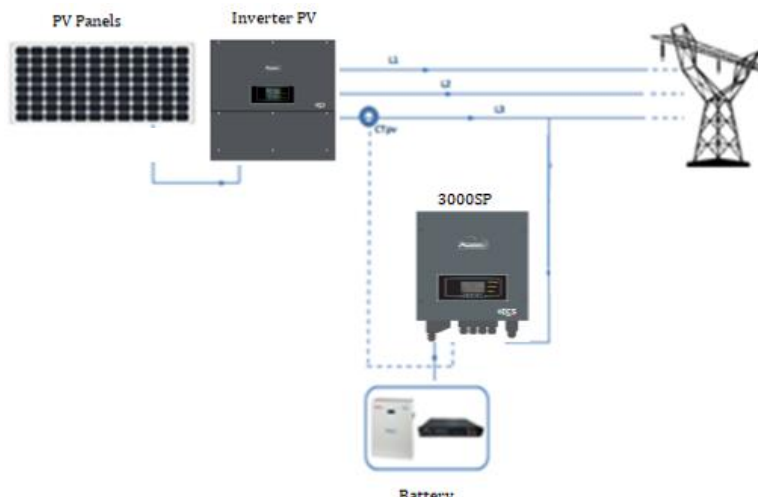

Figure 44 - Diagram of CTpv sensor connection

- 1) If it is necessary to extend the sensor connection cables, use UTP network cables. If there is electric/electronic noise near the cable that may cause interference, use FTP network cables. The cable can be extended by up to 100 metres with a minimum loss of signal.

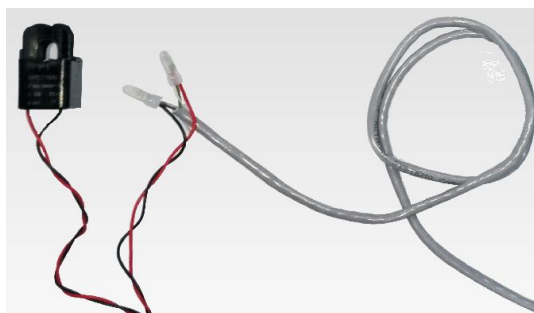

Figure 45 - Extending the cable of the CT current sensor

Below is a reference for connecting the sensors to the CT terminals supplied.

CT cable	Extension (network cable)	Connection to 3000SP
Red	orange / white-orange / brown / white-brown	CT+
Black	green / white-green / blue / white-blue	CT-

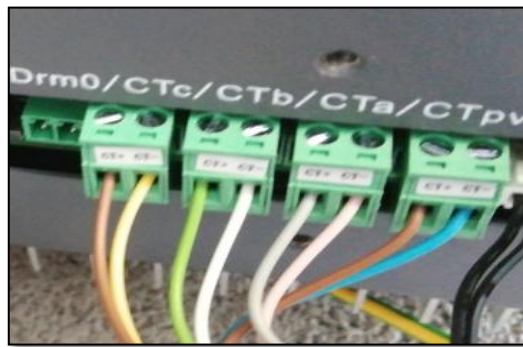
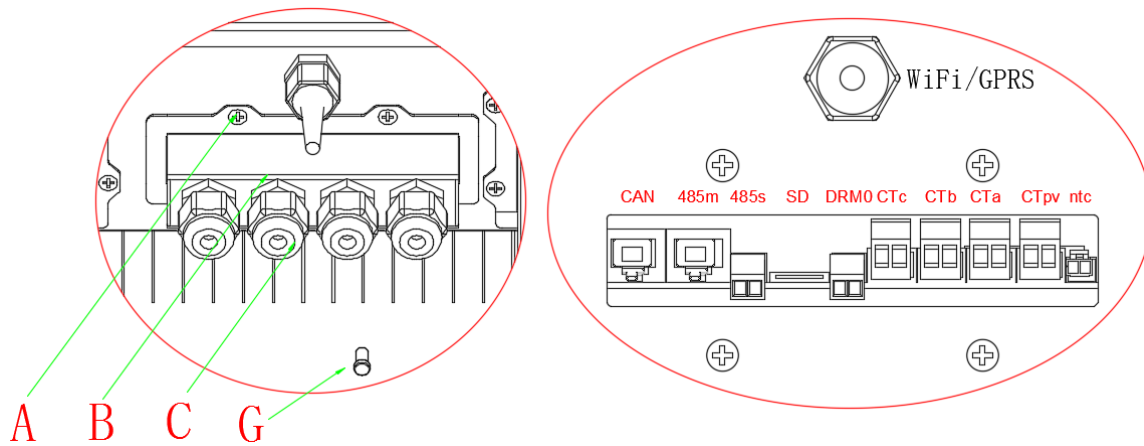

Figure 46 - Connecting the CT cables for the current sensors

- 2) Unscrew the 4 screws (A) of the central cover with a star screwdriver (Figure 46).
- 3) Remove the waterproof cover (B), loosen the cable gland (C), and then remove the stopper (G).
- 4) Route the CT cable through the cable gland to the right of the cover, connect the cable to the CT terminal supplied, then insert the CT terminals into the corresponding ports (CTa for CTb and CTc for the exchange measurement sensors and CTpv for the production sensor).
- 5) For battery connection, refer to the relative paragraph.
- 6) Replace the waterproof cover and secure it with the 4 screws; tighten the cable gland.
- 7) Below are some simplified diagrams showing the correct and incorrect installation of the current sensors.

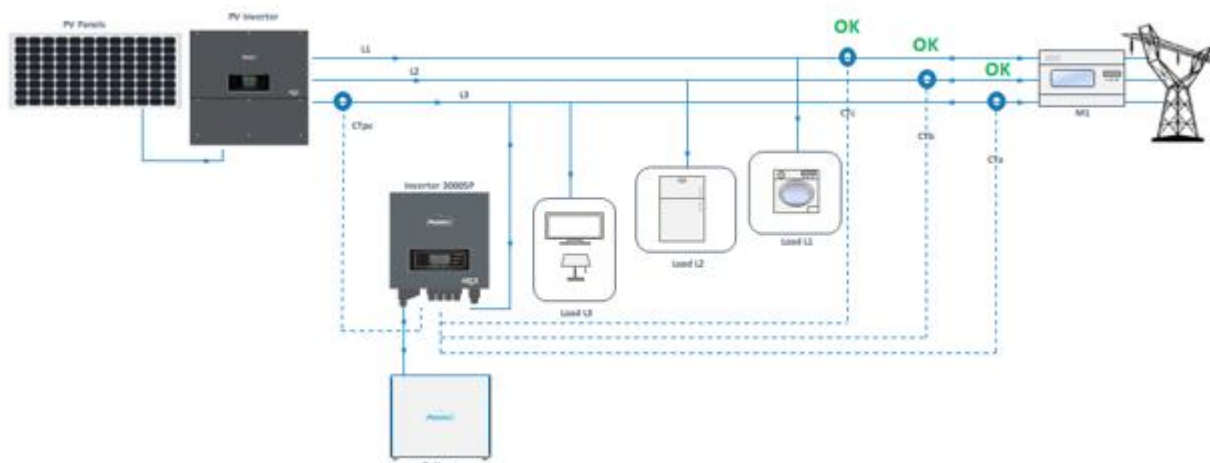

Figure 47 – Correct positioning of the current sensors

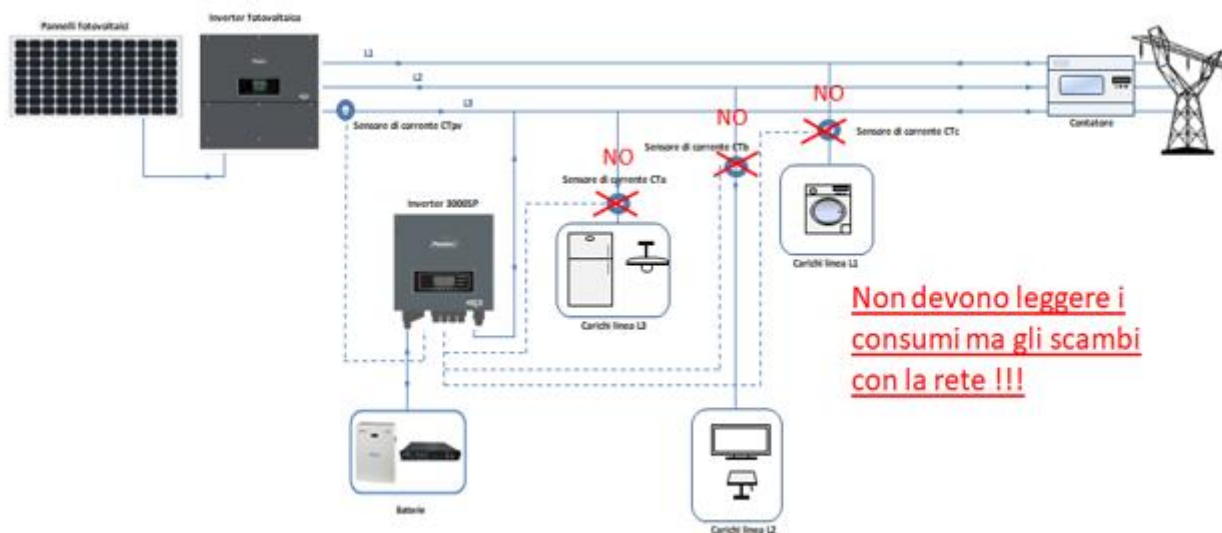

Figure 48 – Incorrect positioning of the current sensors

7.2. Operation

7.2.1. Preliminary checks

Please carry out the following checks before commissioning the inverter.

- 1) The 3000SP inverter must be securely attached to the wall mounting bracket.
- 2) The polarity of the battery cables must be correct and the power cables must be connected securely.

- 3) THE GRID/LOAD cables must be connected securely and correctly to the corresponding terminal block.
- 4) The AC switch must be connected correctly between the inverter's GRID port and the grid. The automatic AC switch must be set to OFF.
- 5) In the case of connection to the EPS, make sure that the AC power contactor is connected correctly.
- 6) For lithium batteries, make sure that the communication cable has been connected correctly.

7.2.2. First start-up of the inverter

1. Switch off the photovoltaic system and any other energy generation from renewable sources; this can be done by disconnecting the AC power to the photovoltaic inverter by means of the disconnecting switch installed on the system. Alternatively, the production inverter can be disconnected on the DC side via the switch on board the inverter or the one specifically installed in the system.
2. Make sure that the utility has a consumption of more than 500 W on each phase. Recommended loads for this operation are hair dryers (800W < P < 1600W), electric heaters (1000W < P < 2000W) and ovens (P > 1500W). Other types of loads, such as washing machines or heat pumps, although characterised by high energy consumption, may take some time to reach this level of absorption after starting.

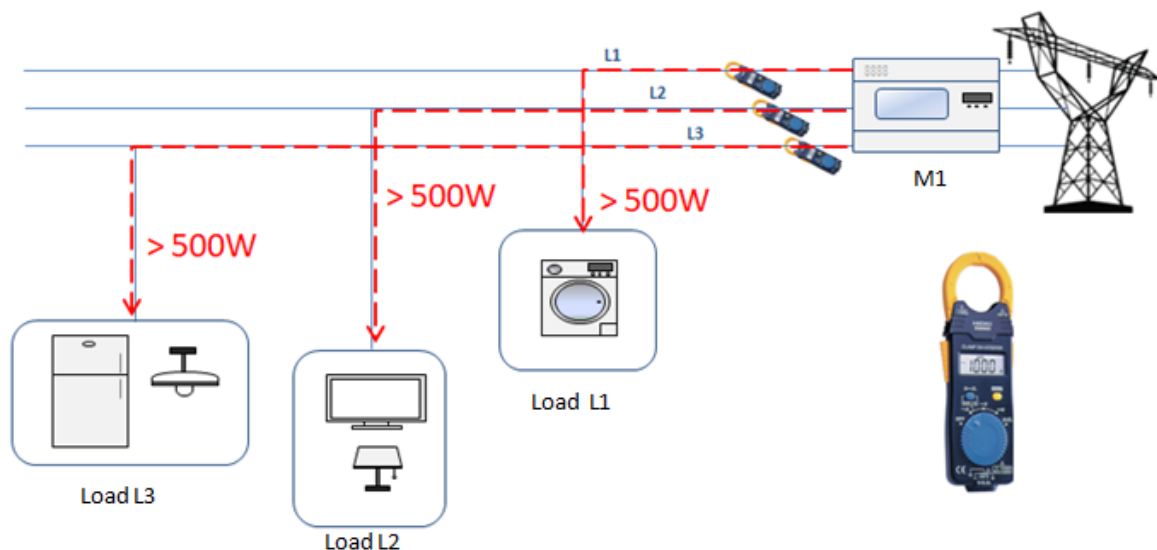

Figure 49 – Checking that absorption is greater than 500W on each of the three phases

4. Start the 3000 SP storage inverter

- Supply DC power to the inverter by correctly switching on the batteries:

In the case of Pylontech batteries, set the POWER switch of the battery, or (in the case of multiple units) of all the batteries, to I (ON position), then press the red SW button of the master battery for about one second; at this point the LEDs of all the batteries will light up in sequence, and after a few seconds will turn off, except for the RUN indicating LED.



Figure 50 – Battery status after setting the POWER switch to ON and pressing the SW button

In the case of WeCo batteries, press the RUN button for about one second; after releasing it, wait for the sound inside the battery indicating the closure of the relay. Repeat the operation for all the subsequent batteries in the system.



Figure 51 - View of WeCo battery ON button

- Supply AC power through the dedicated protection switch of the storage inverter. If there is more than one switch protecting the inverter (e.g. a circuit breaker and differential switch), they must all be set to ON to allow the inverter to be connected to the grid.



Figure 52 – Example of AC switch protecting the inverter

7.2.3. “FREEZING” current sensors

Starting from firmware version 1.94, the “CT Direction” function is available on the display, which allows faster and more correct installation and configuration of the current sensors.

This can be done once the inverter has been started by following these steps:

7. Press the ESC/Menu key (first key from the left) to enter the main menu.
8. Use the Enter key (fourth key from the left) to enter the “1. Settings” submenu and scroll down with the arrow until the “CT Direction” item is highlighted. Press the Enter key.

Enter the password **0001** using the up and down arrow keys to change the highlighted value by one unit and the ENTER key to move to the next value.

9. A screen similar to the one below will appear.

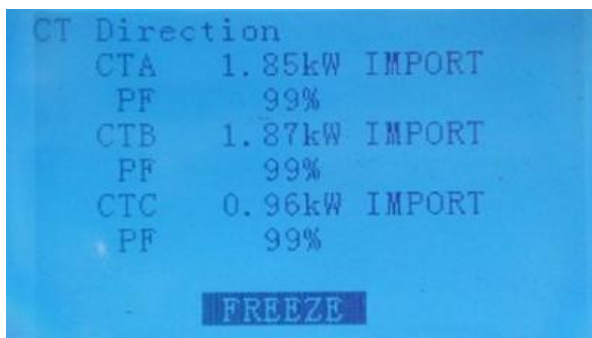

Figure 53 – Screen relating to the CT Direction submenu

For each of the three sensors installed, the three lines show the reading of the power measured, the direction of this power and the Power Factor; for example, the figure shows a CTA sensor reading equal to 1.85 kW being imported from the grid towards the utility; in this case, the Power Factor indicates the phase shift of the current measured with respect to the voltage and this parameter helps to understand if the sensor is on the correct phase in case of installation on a three-phase system.

The measurements taken by the current clamp, as shown in the previous procedure, can therefore be replaced by the power readings shown in this menu. Therefore, when turning on the system (or during the initialisation), it is necessary to make sure that all three phases have a power of more than 500W in IMPORT conditions in order to correctly direct the three phases.

You can check whether the sensor has been installed on the correct phase by means of the Power Factor: Power Factor values higher than 90% indicate that the sensor connected to this input (e.g. the CTb sensor) is positioned on the correct phase.

NOTE: To ensure a correct reading of the Power Factor, an absorption of more than 700W is needed, as lower powers could affect the reading sensitivity of the sensor, thus distorting the PV calculation.

If in these conditions the sensors are not correctly positioned on the phases of the system, the Power Factor value will be considerably lower than 60%, and the alarm signal will appear <!> as shown below.

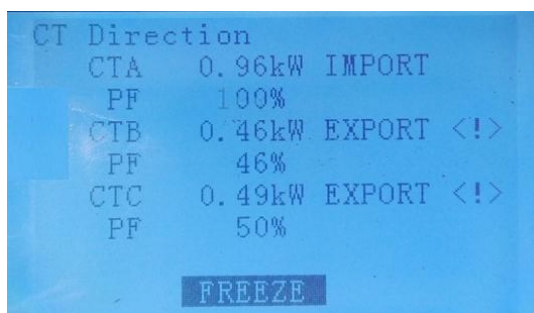

Figure 54 – CTb and CTC sensors installed on incorrect phases

Therefore, it will only be necessary to invert the probes with low PV, or equivalently the terminals inserted in the inverter's terminal block until the Power Factor value takes on the correct values (shown in figure 6).

If it is not possible to obtain the required conditions, contact the ZCS Service Centre on the toll-free number 800 72 74 64 (only available in Italy) or open a ticket by going to the support section of our website at <https://www.zcsazzurro.com/it/support>.

10. When the appropriate start-up conditions (imported power > 500 W and PV > 90% 90% on all phases) have been met, it will be possible to “freeze” this situation so that it does not have to be repeated on future system start-ups.
 - a. Press the second key ↑ to display the FREEZE message at the bottom
 - b. Press ENTER to confirm.

The FREEZE option will be activated, blocking the direction of the sensors and making subsequent machine start-ups faster and easier.

In case of error during the start-up procedure and incorrect direction of the sensor, it is possible to cancel the FREEZE operation by simply entering into the CT direction menu and changing the FREEZE option to UNFREEZE, using the up arrow key and confirming with the ENTER key.

11. Exit the menu with the ESC/MENU key to return to the main interface.

The initial start-up procedure is now complete and does not have to be repeated when the machine is restarted in the future.

7.2.4. Setting CTpv in three-phase mode

1.Settings	
	13.CTpv Scale Factor

Table 4 – Settings Menu

1. Press the ESC/Menu key (first key from the left) to enter the main menu.
2. Use the Enter key (fourth from the left) to enter the “1. Settings” submenu and scroll down with the arrow until the “CTpv Scale Factor” item is highlighted. Press the Enter key.
3. Enter the password 0001 using the up and down arrow keys to change the highlighted value by one unit and the ENTER key to move to the next value.
4. Use the arrows again and the Enter key to set the multiplication value to be applied to the reading of the CTpv; set a value of 3.00, as shown in the figure below. Confirm with the ENTER key.

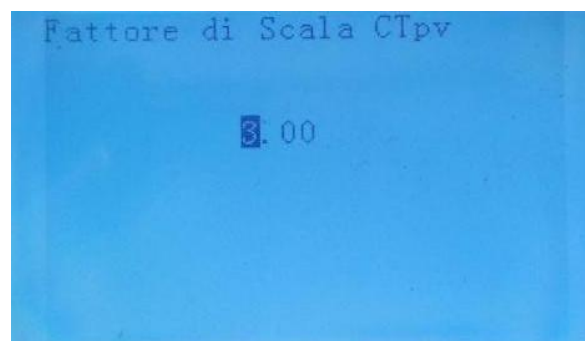

Figure 55 – Setting of the CTpv Scale Factor from the display

5. Use the Esc/Menu key to go back to the main interface.
6. Switch on the photovoltaic inverter so that it can start producing energy.



Figure 56 - Switching on the photovoltaic inverter

8. Verification of proper functioning

To check the proper functioning of the inverter, follow these steps:

1. Switch of all photovoltaic generation sources.



2. Lower the circuit breaker switch dedicated to protecting the 3000SP, the inverter will remain switched on but will go into error due to no alternating power.



3. Power up the 3000SP by pulling on the AC switch.



4. After pulling up the AC switch, the countdown will start according to the country code set (for CEI021-Internal, it will be 300s) to reconnect to the grid. During this period, check that the household loads are only powered by the grid and that there are no other power flows from either the photovoltaic system or the battery.

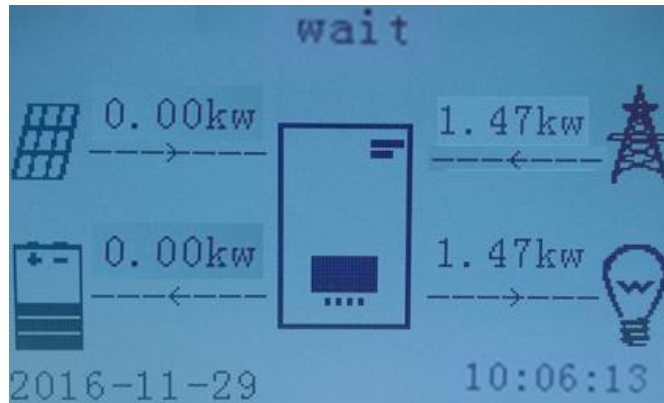

5. Once the countdown is over, the batteries will start to deliver power according to the availability towards the utility, trying to reset the consumption from the grid. During this period, check that the
 - a. value of the consumption remains constant* as the power supplied by the battery increases during discharge.
 - b. The power taken from the grid should decrease by an amount equal to the power supplied by the battery.
 - c. The photovoltaic value on the display remains zero.

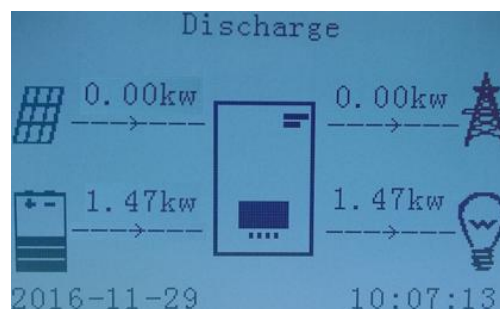

6. Switch on the photovoltaic inverter.



7. Once the photovoltaic system has been activated, check that:
 - a. The value of consumption shown on the screen remains constant as the photovoltaic power increases.
 - b. Depending on the photovoltaic production, the system will operate according to the system's working mode.
 - c. The value of PV production shown on the display is in line with the real photovoltaic production visible on the photovoltaic inverter.

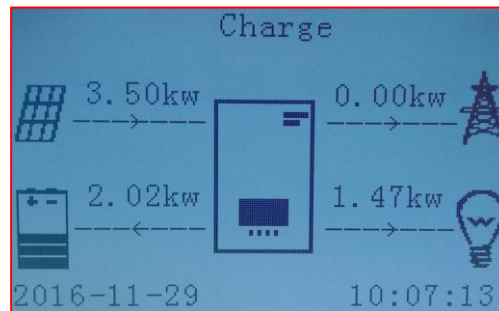

8. If the above are not verified, check the CT positioning and direction by consulting the sections on correct installation and initial start-up.

8.1. Checking the settings

1. Below is a summary of all the settings on the device, which you can find in the system info menu. In particular, check that the parameters indicated are correct. To access this menu, from the main screen:
 - 1.1. Press the first key from the left;
 - 1.2. Press the third ↓ key twice;
 - 1.3. Enter the “System Info” menu by pressing the fourth key;
 - 1.4. To scroll through the images, press the third ↓ key.

Info Sistema (1)		Info Sistema (2)	
Seriale :	ZE1ES330J28307	Paese :	CEIO-21 Internat
Versione Software :	V1.00	Codice Servizio :	V2.00
Versione Hardware :	V1.00	EPS :	Abilitato 7s
Indirizzo RS485 :	01	Modalità di lavoro :	Modalità automatica

RS485 Address: check that it has a value of 01 so that you can monitor your systems via the app or website.

Country: Check that the country code is correct for the regulation in force.

EPS Mode: (Enabled/Disabled).

Working mode: in order to minimise exchanges with the grid, the correct mode will be “Automatic Mode.”

Info Sistema (3)		Info Sistema (4)	
Controllo DRMs0 :	Disabilitato	Fattore di Scala CTpv:	1.00
Imposta tempo PF :		CT Direction:	Unfrozen
DFLT : 0.000s	SET : 0.000s		
Imposta tempo QV :			
DFLT : 3.0s	SET : 3.0s		
Fattore Potenza:	100%		

DRMs0 Control (or Logical Interface): must be disabled.

CTpv Scale Factor:

1.00 → Single-phase configuration

3.00 → Three-phase configuration

CT Direction check the blocking status of the CTs.

Info Batteria (1)		Info Batteria (1)	
Tipo Batteria :	Pylon	Tipo Batteria :	WeCoHeSU V0.3.54
Capacità Batteria :	50Ah	Capacità Batteria :	86Ah
Profondità Scarica :	80% (EPS) 80%	Profondità Scarica :	80% (EPS) 90%
Corr. Carica max (A) :	BMS : 25.00A SET : 65.00A	Corr. Carica max (A) :	BMS : 65.00A SET : 65.00A

Battery type: check if the battery model on the display is consistent with the batteries installed.

Battery capacity: the system will show the total capacity of the batteries:

- Pylontech 1 → 50 Ah;
- Pylontech 2 → 100Ah
- Pylontech n → n x 50Ah
- WeCo 1 → 86 Ah;
- WeCo 2 → 172Ah
- WeCo n → n x 86Ah

Depth of discharge: check the depth of discharge values set in On-grid and EPS mode.



Info Batteria (2)		Info Batteria (2)	
Soglia sovratensione :	54.0V	Soglia sovratensione :	59.3V
Soglia carica max (V) :	53.2V	Soglia carica max (V) :	58.4V
Corr. max Scarica (A) :		Corr. max Scarica (A) :	
BMS : 25.00A SET : 65.00A		BMS : 65.00A SET : 65.00A	
Tensione min scarica :	47.0V	Tensione min scarica :	48.0V



9. Technical specifications

TECHNICAL DATA		3000SP
Battery connection technical data		
Type of compatible battery	Lithium-ion (supplied by Zucchetti)	
Rated voltage	48V	
Allowable voltage range	42V-58V	
Recommended battery capacity	50Ah- 200Ah	
Maximum charge/discharge power	3000W	
Allowable temperature range*	-10°C-50°C	
Maximum charge current	65A (programmable)	
Maximum discharge current	65A (programmable)	
Charge curve (Lithium)	Managed by the battery's BMS	
Depth of Discharge (DoD)	Lithium-ion: 0%-90% (programmable);	
AC input (grid side)		
Rated power	3000W	
Maximum Power	3000VA	
Maximum current	13A	
Connection type/Rated voltage	Single-phase L/N/PE 220, 230, 240V	
AC voltage range	180V-270V (according to the local standards)	
Rated frequency	50Hz/60Hz	
AC frequency range	44Hz -55Hz / 54Hz -66Hz (according to the local standards)	
Total harmonic distortion	< 3%	
Power factor	1 default (Programmable +/- 0.8)	
EPS Output (Emergency Power Supply)		
Power supplied in EPS mode** in the absence of photovoltaic production	3000VA	
EPS output voltage and frequency	230V 50Hz/60Hz	
Current supplied in EPS mode	13A	
Total harmonic distortion	< 3%	
Switch time	< 3s default (programmable from 1 to 999s)	
Efficiency		
Maximum charge efficiency	94.1%	
Maximum discharge efficiency	94.3%	
Consumption in stand-by	< 5W	
Protections		
Internal interface protection	Yes	
Safety protections	Anti-islanding, RCMU, Ground Fault Monitoring	
Overheating protection	Yes	
Overvoltage category/Protective class	Overvoltage Category III / Protective class I	
Battery soft start	Yes	
Standard		
EMC	EN 61000-6-1/2/3/4,	
Safety standard	IEC 62116, IEC 61727, IEC 61683, IEC 60068-1/2/14/30, IEC 62109-1/2	
Grid connection standard	CEI 0-21, RD1699, AS4777, VDE 0126-1-1, G83/2, EN50438, VDE-AR-N4105, UTEC15/712-1	
Communication		
Communication interfaces	Wi-Fi, RS485 (proprietary protocol), SD card, CAN 2.0 (for battery connection)	
Additional inputs or connections	Input for DC current sensor connection + 3 inputs for AC current sensor connection	
Data storage on SD	25 years	
General data		
Allowable ambient temperature range	-25°C...+60°C (power limit above 45°C)	
Topology	High-frequency isolation	
Environmental protection class	IP65	
Allowable relative humidity range	0%.....95% non-condensing	
Maximum operating altitude	2000m	
Noise level	< 25dB @ 1mt	
Weight	16Kg	
Cooling	Natural convection	
Dimensions (H x L x D)	532mm x 360mm x 173mm	
Display	LCD	
Warranty	5 or 10 years	

* Standard value for lithium batteries; maximum operating range between +10°C/+40°C

** Power output in EPS mode depends on the type of batteries and the status of the system (e.g. residual capacity, temperature)

10. Troubleshooting and maintenance

10.1. Troubleshooting

This section contains information and procedures on how to troubleshoot any faults and errors that may occur during operation of the 3000SP storage inverter.

If you have any problems with the inverter, please follow these steps.

- Is the inverter located in a clean, dry and properly ventilated place?
- Is the battery switched ON?
- Are the cables correctly sized and as short as possible?
- Are the input/output connections and the cables in good condition?
- Are the configuration settings correct for the type of installation?
- Are the display panel and flat communication cable correctly connected and not damaged?

Follow the steps below to display the recorded alarms:

Press “Menu/Back” to enter the main menu from the standard interface. Select “Event List” in the menu screen, then press “OK” to access the list of alarms and errors.

Error code	Error name	Error description	Possible solution
ID01	GridOVP	Grid voltage is too high.	<p>If these errors occur occasionally, the cause may be that the grid voltage is outside the standard parameters. The 3000SP inverter will automatically return to normal operation when the grid is within the normal range again.</p> <p>If the alarms are frequent, it is recommended to measure the voltage/frequency at the terminals to check their values. If the values are within the normal range and the error persists, contact Technical Support.</p> <p>If the values are outside the normal range, check the wiring to the AC circuit breaker.</p> <p>The overvoltage / undervoltage / overfrequency / underfrequency trip thresholds can be changed according to and with the approval of the local grid operator. Contact Technical Support to perform this operation.</p>
ID02	GridUVP	Grid voltage is too low	
ID03	GridOFP	Grid frequency is too high	
ID04	GridUFP	Grid frequency is too low	

ID05	BatOVP	Battery voltage is too high	If the alarm is sporadic and not consistent, check the battery overvoltage setting and compare it with the datasheet of the battery. If the setting is correct and the alarm persists, contact Technical Support.
ID06	Vlvrtlow	LVRT function error	Contact Technical Support
ID07	Vovrthigh	OVRT function error	
ID08	PVOVP	PV voltage is too high	<p>Check whether there are too many photovoltaic modules connected in series to a string:</p> <p>the string voltage (Voc) is higher than the maximum input voltage allowed by the inverter. Adjust the number of photovoltaic modules connected in order to reduce the PV production.</p> <p>The inverter automatically returns to its normal operating state after the appropriate corrections.</p>
ID09	HW_LLCB us_OVP	Voltage on LLC line is too high. Hardware protection trip	<p>ID09- ID26: Internal errors of the 3000SP inverter.</p> <p>Switch off the unit by disconnecting the AC and DC switches, and wait for at least 5 minutes. Switch the unit back on again by closing the AC and DC switches, and check if the error is still present. If so, contact Technical Support.</p>
ID10	HW_Boost_OVP	Boost voltage is too high. Hardware protection trip	
ID11	HwBuckBoostOCP	BuckBoost current is too high. Hardware protection trip	
ID12	HwBatOCP	Battery current is too high. Hardware protection trip	
ID15	HwAcOCP	Grid current is too high. Hardware protection trip	

ID17	HwADFaultGrid	Sampling error of the grid current		
ID18	HwADFaultDCI	DCI sampling error		
ID19	HwADFaultVGrid	Sampling error of the grid voltage		
ID20	GFCIDeviceFault	GFCI sampling error.		
ID21	MChip_Fault	Microprocessor fault		
ID22	HwAuxPowerFault	Error on the auxiliary supply voltage		
ID25	LLCBusOVP	Voltage on LLC line is too high.		
ID26	SwBusOVP	Voltage on the communication line is too high. Software protection trip		
ID27	BatOCP	Battery current is too high.		If the error occurs frequently, contact Technical Support.
ID28	DciOCP	Current on the DCI is too high		<p>ID28-ID31 are internal errors of the 3000SP.</p> <p>Switch off the unit by disconnecting the AC and DC switches, and wait for at least 5 minutes. Switch the unit back on again by closing the AC and DC switches, and check if the error is still present. If the error persists, contact Technical Support.</p>
ID29	SwOCPInstant	Grid current is too high.		
ID30	BuckOCP	Current on the Buck is too high		
ID31	AcRmsOCP	Output current is too high.		
ID34	Overload	Overload	Adjust the load power in the correct range.	
ID35	CT Fault	The CT is faulty	Check whether the CT is stable and has been directed correctly.	
ID49	Consistent Fault_VGrid	Grid voltage measurements between the main DSP and the secondary DSP are not aligned	<p>ID49-ID51 are internal errors of the 3000SP.</p> <p>Switch off the unit by disconnecting the AC and DC switches, and wait for at least 5 minutes. Switch the unit back on again by closing the AC and DC switches,</p>	

ID50	Consistent Fault_FGrid	Grid frequency measurements between the main DSP and the secondary DSP are not aligned	and check if the error is still present. If the error persists, contact Technical Support.
ID51	Consistent Fault_DCI	DCI measurements between the main DSP and the secondary DSP are not aligned	
ID52	BatCommunicationFlag	Communication error with the battery	3000SP does not communicate with the BMS correctly. Make sure that the battery you are using is compatible with the 3000SP inverter. Make sure you have selected the correct battery type and check the communication cable between the battery and the 3000SP inverter.
ID53	SpiCommLoss	SPI communication error	ID65-ID77 are internal errors of the 3000SP inverter. Switch off the unit by disconnecting the AC and DC switches, and wait for at least 5 minutes. Switch the unit back on again by closing the AC and DC switches, and check if the error is still present. If so, contact Technical Support.
ID54	SciCommLoss	SCI communication error	
ID55	RecoverRelayFail	Relay error	
ID57	OverTemp Fault_BAT	Battery temperature is too high	
ID58	OverTemp Fault_Heat Sink	Inverter heat sink temperature is too high	
ID59	OverTemp Fault_Env	Ambient temperature is too high.	
ID65	unrecoverHwAcOCP	Grid current is too high. Unrecoverable hardware fault	
ID66	unrecoverBusOVP	Bus voltage is too high. Unrecoverable hardware fault	
ID67	BitEPSunrecoverBatOCP	Unrecoverable fault on the battery in EPS mode	

ID70	unrecover OCPIstan t	Grid current is too high. Unrecoverable hardware fault	
ID75	unrecover EEPROM_ W	Unreadable EEPROM	
ID76	unrecover EEPROM_ R	Unreadable EEPROM	
ID77	unrecover RelayFail	Permanent fault on relays	
ID81	Over Temperatu re	Internal temperature is too high.	1) Check that the 3000SP inverter is installed in a place without direct sunlight / other heat sources. 2) Check that the 3000SP inverter is installed vertically and that the ambient temperature is less than that allowable by the 3000SP
ID82	Over Frequency	AC frequency is too high.	Refer to ID01
ID83	Long dist Load Shedding	Remote signal of load limit	The 3000SP inverter receives a remote signal to limit the load.
ID84	Long dist OFF	Shutdown signal of the 3000SP inverter	Switch of the inverter and contact technical support.
ID85	Battery Voltage is low	Battery voltage is low	Minimum voltage level has been reached. It will not be possible to discharge the battery any further unless it is recharged.
ID86	Bat Voltage Low Shut	Battery voltage is low.	The inverter shuts down when the battery voltage is too low.
ID94	Software version is not consistent	The firmware version installed is not suitable for the type of inverter.	Contact Technical Support
ID95	CommEEP ROMFault	EEPROM of the communication board cannot be read	ID95-ID96 are internal errors of 3000SP Switch off the unit by disconnecting the AC and DC switches, and wait for at least 5 minutes. Switch the unit back on again by closing the AC and DC switches, and check if the error is still present. If so, contact Technical Support.
ID96	RTCFault	Clock error	
ID97	InValidCou ntry	Country selected is not valid	Check the country code setting

ID98	SDfault	SD card error	Extract the SD card and clean it with a dry cloth. If the error persists, replace the SD card with a new one.
ID99	Wi-Fi fault	The Wi-Fi is in error	Contact Technical Support
ID100	BatOCD	Overcurrent protection of battery discharge	ID100-ID103 are battery errors. If the case of occasional errors, wait a few minutes to see if the error disappears. If the error persists, contact Technical Support.
ID101	BatSCD	Short circuit protection of battery discharge	
ID102	BatOV	Battery overvoltage protection	
ID103	BatUV	Battery undervoltage protection	
ID104	BatOTD	Over-temperature protection of battery discharge	ID106-ID107 are battery errors. Check the conditions of installation and ventilation of the battery. Alternatively, reduce the charge and discharge current value set. If the error persists, contact Technical Support.
ID105	BatOTC	Over-temperature protection of battery charge	
ID106	BatUTD	Under-temperature protection of battery discharge	ID106-ID107 are battery errors. Check the installation and ventilation conditions of the battery. If the error persists, contact Technical Support.
ID107	BatUTC	Under-temperature protection of battery charge	

10.2. Maintenance

Inverters generally do not require daily or routine maintenance. In any case, for proper long-term operation of the inverter, make sure that the heatsink for cooling the inverter has enough space to ensure adequate ventilation and that it is not obstructed by dust or other items.

Cleaning the inverter

Use an air compressor, a soft dry cloth or a soft-bristled brush to clean the inverter. Do not use water, corrosive chemicals or aggressive detergents to clean the inverter. Disconnect the AC and DC power to the inverter before performing any cleaning operations.

Cleaning the heatsink

Use an air compressor, a soft dry cloth or soft-bristled brush to clean the heatsink. Do not use water, corrosive chemical substances or aggressive detergents to clean the heatsink. Disconnect the AC and DC power to the inverter before performing any cleaning operations.

11. Uninstalling

11.1. Uninstallation steps

- Disconnect the inverter from the AC grid.
- Disconnect the DC switch (located on the battery or installed on the wall)
- Wait 5 minutes
- To remove the DC connectors from the inverter
- Remove the connectors for communication with the batteries and current sensors.
- Remove the AC terminals.
- Unscrew the fixing bolt of the bracket and remove the inverter from the wall.

11.2. Packaging

If possible, pack the inverter in its original packaging.

11.3. Storage

Store the inverter in a dry place where the ambient temperature is between -25 and +60°C.

11.4. Disposal

Zucchetti Centro Sistemi S.p.a. is not liable for the disposal of the equipment, or parts thereof, that does not take place according to the regulations and standards in force in the country of installation.



The symbol of the crossed-out wheeled bin indicates that the equipment, at the end of its useful life, must be disposed of separately from household waste.

This product must be handed over to the waste collection point in your local community for recycling.

For more information, please contact the waste collection authority in your country.

Inappropriate waste disposal could have negative effects on the environment and on human health due to potentially hazardous substances.

With your cooperation in the correct disposal of this product, you contribute to the reuse, recycling and recovery of the product, and to the protection of our environment.

12. Monitoring systems

12.1. External Wi-Fi adapter

12.1.1. Installation

Unlike the internal Wi-Fi card, the external adapter must be installed for all compatible inverters. However, the procedure is quicker and easier as there is no need to open the front cover of the inverter.

In order to monitor the inverter, the RS485 communication address must be set to 01 directly from the display.

Installation tools:

- Cross screwdriver
 - External Wi-Fi adapter
- 1) Switch off the inverter following the procedure described in this manual.
 - 2) Remove the cover for accessing the Wi-Fi connector on the bottom of the inverter by unscrewing the two cross-head screws (a), or by unscrewing the cover (b), as shown in the figure.



Figure 57 – Port for external Wi-Fi adapter

- 3) Connect the Wi-Fi adapter to the appropriate port, making sure to follow the direction of the connection and ensure correct contact between the two parts.

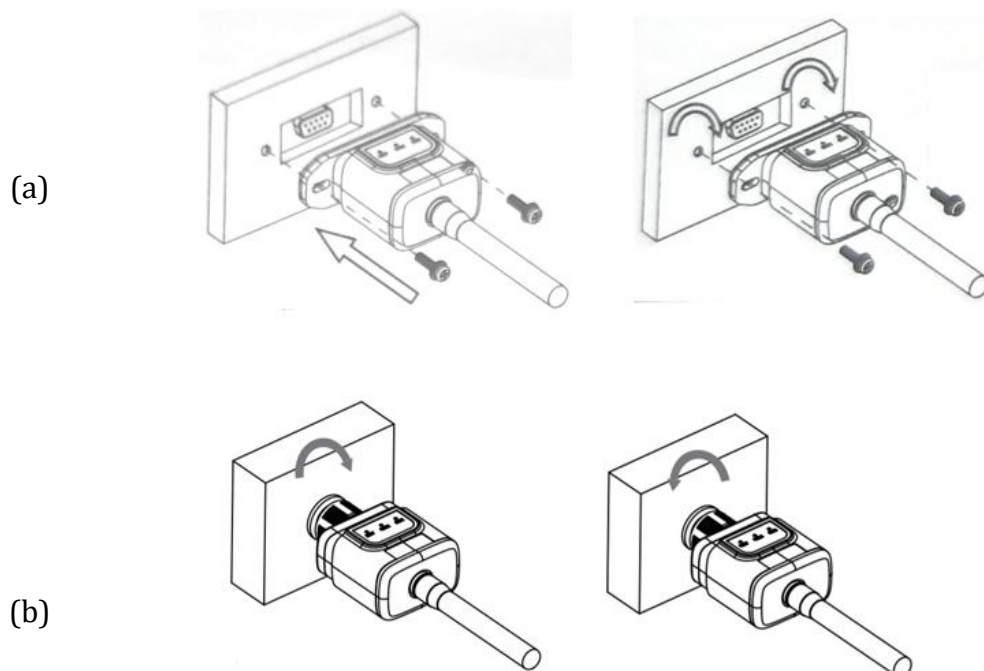

Figure 58 – Inserting and securing the external Wi-Fi adapter

- 4) Switch on the inverter by following the procedure described in the manual.

12.1.2. Configuration

Configuration of the Wi-Fi adapter requires the presence of a Wi-Fi network near the inverter in order to achieve stable transmission of data from the inverter adapter to the Wi-Fi modem.

Tools required for configuration:

- Smartphone, PC or tablet

Go to front of the inverter and search for the Wi-Fi network using a smartphone, PC or tablet, making sure that the signal from the home Wi-Fi network reaches the place where the inverter is installed.

If the Wi-Fi signal is present at the location where the inverter is installed, the configuration procedure can begin.

If the Wi-Fi signal does not reach the inverter, a system must be installed to amplify the signal and bring it to the installation location.

- 1) Activate the search for the Wi-Fi networks on your telephone or PC so that all the networks visible by your device are displayed.



Figure 59 - Search for Wi-Fi networks on iOS smartphone (left) and Android smartphone (right)

Note: Disconnect from any Wi-Fi networks to which you are connected by removing automatic access.



Figure 60 – Disabling automatic reconnection to a network

- 2) Connect to a Wi-Fi network generated by the inverter's Wi-Fi adapter (i.e. AP_*****, where ***** indicates the serial number of the Wi-Fi adapter shown on the label of the device), which operates as an access point.

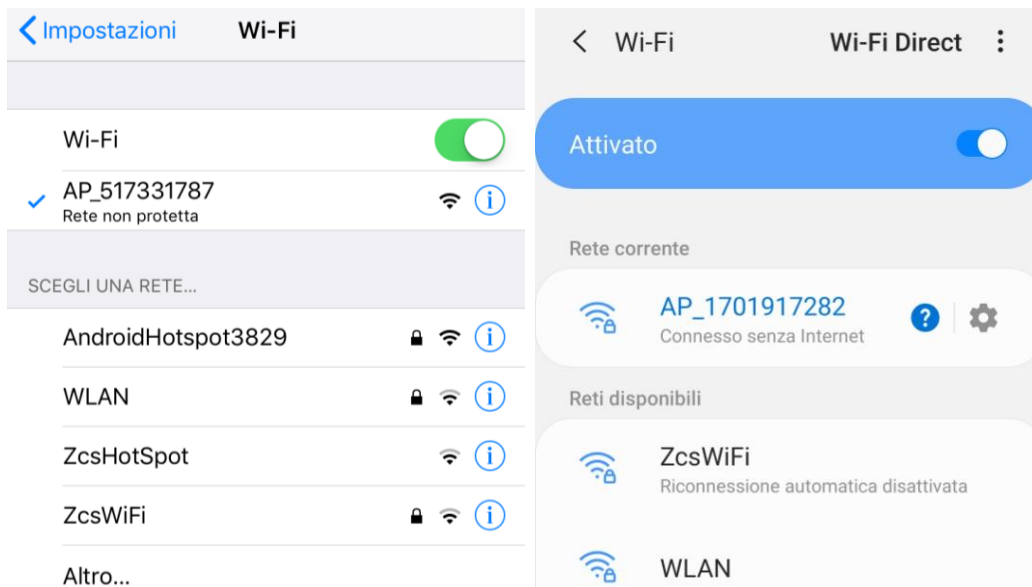

Figure 61 - Connection to Access Point for Wi-Fi adapter on iOS smartphone (left) and Android smartphone (right)

- 3) If you are using a second-generation Wi-Fi adapter, you will be prompted for a password to connect to the inverter's Wi-Fi network. Use the password found on the box or on the Wi-Fi adapter.



Figure 62 – Password of external Wi-Fi adapter

Note: To ensure that the adapter is connected to the PC or smartphone during the configuration procedure, enable automatic reconnection of the AP_***** network.

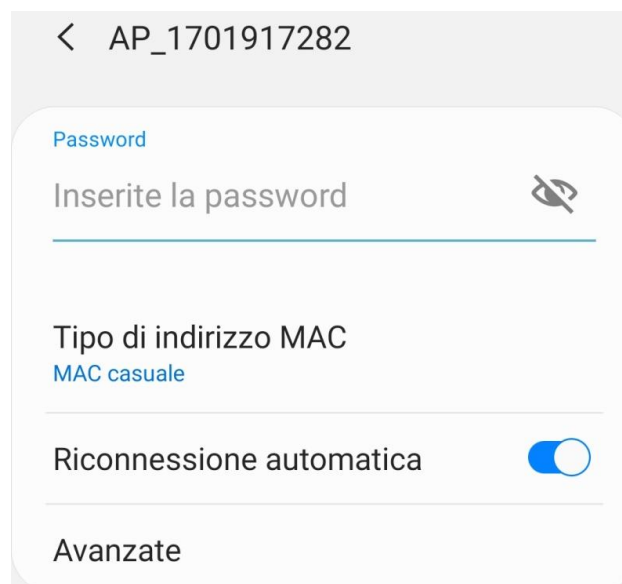

Figure 63 – Password entry prompt

Note: the Access Point is not able to provide internet access; confirm to maintain the Wi-Fi connection, even if the internet is not available

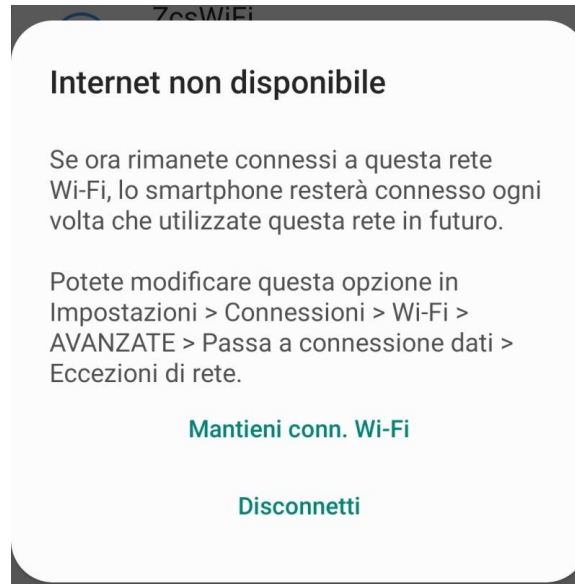

Figure 64 – Screen indicating that the Internet cannot be accessed

- 4) Open a browser (Google Chrome, Safari, Firefox) and enter the IP address 10.10.100.254 in the address bar at the top of the screen.
In the box that appears, enter “admin” as both the Username and Password.

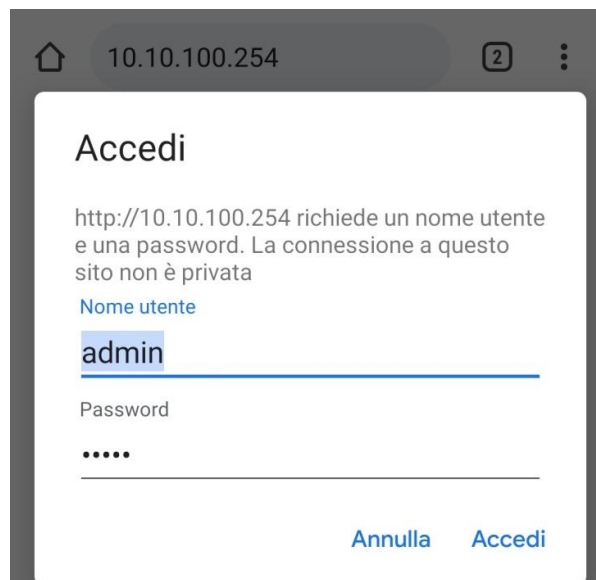
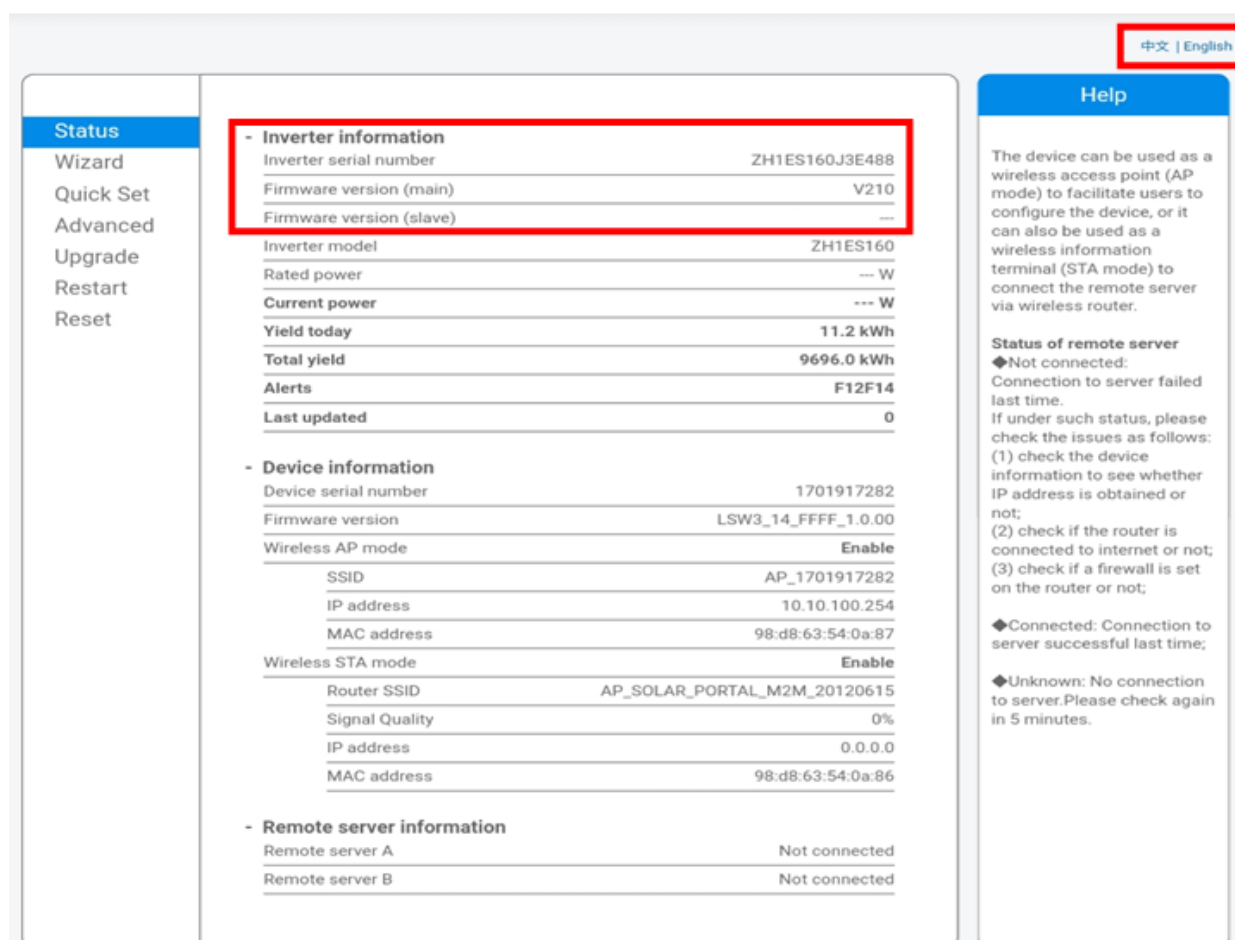

Figure 65 – Screen for accessing the web server to configure the Wi-Fi adapter

- 5) The status screen will open, showing the logger information such as the serial number and firmware version.

Check that the Inverter Information fields are filled in with the inverter information.

The language of the page can be changed using the command in the top right-hand corner.



The screenshot shows the 'Status' screen of a device. At the top right, there is a language selection button with '中文 | English'. The main content is divided into three sections: Inverter information, Device information, and Remote server information. The 'Inverter information' section is highlighted with a red box. The 'Device information' section includes details for both Wireless AP mode and Wireless STA mode. The 'Remote server information' section shows two servers, both of which are 'Not connected'.

- Inverter information	
Inverter serial number	ZH1ES160J3E488
Firmware version (main)	V210
Firmware version (slave)	---
Inverter model	ZH1ES160
Rated power	--- W
Current power	--- W
Yield today	11.2 kWh
Total yield	9696.0 kWh
Alerts	F12F14
Last updated	0

- Device information	
Device serial number	1701917282
Firmware version	LSW3_14_FFFF_1.0.00
Wireless AP mode	Enable
SSID	AP_1701917282
IP address	10.10.100.254
MAC address	98:d8:63:54:0a:87
Wireless STA mode	Enable
Router SSID	AP_SOLAR_PORTAL_M2M_20120615
Signal Quality	0%
IP address	0.0.0.0
MAC address	98:d8:63:54:0a:86

- Remote server information	
Remote server A	Not connected
Remote server B	Not connected

Figure 66 – Status screen

- 6) Click on the Wizard setup button in the left-hand column.
- 7) In the new screen that opens, select the Wi-Fi network to which you want to connect the Wi-Fi adapter, making sure that the Received Signal Strength Indicator (RSSI) is greater than 30%. If the network is not visible, press the Refresh button.

Note: check that the signal strength is greater than 30%, if not, bring the router closer or install a repeater or signal amplifier.
Click Next.

Please select your current wireless network:

Site Survey

SSID	BSSID	RSSI	Channel
<input checked="" type="radio"/> iPhone di Giacomo	EE:25:EF:6C:31:18	100	6
<input type="radio"/> ZcsWiFi	FE:EC:DA:1D:C3:9	86	1
<input type="radio"/> ZcsHotSpot	FC:EC:DA:1D:C3:9	86	1
<input type="radio"/> WLAN	E:EC:DA:1D:C3:9	86	1
<input type="radio"/> ZcsHotSpot	FC:EC:DA:1D:C8:A3	57	11
<input type="radio"/> WLAN	E:EC:DA:1D:C8:A3	57	11
<input type="radio"/> ZcsWiFi	FE:EC:DA:1D:C8:A3	54	11
<input type="radio"/> WLAN	E:EC:DA:1D:C8:8B	45	1
<input type="radio"/> ZcsWiFi	FE:EC:DA:1D:C8:8B	37	1
<input type="radio"/> ZcsHotSpot	FC:EC:DA:1D:C8:8B	35	1

★Note: When RSSI of the selected WiFi network is lower than 15%, the connection may be unstable, please select other available network or shorten the distance between the device and router.

Refresh

Add wireless network manually:

Network name (SSID)
(Note: case sensitive)

Encryption method

Encryption algorithm

Next

1 2 3 4

Figure 67 – Screen for selecting the available wireless network (1)

- Enter the password of the Wi-Fi network (Wi-Fi modem), clicking on Show Password to make sure it is correct; the password should not contain special characters (&, #, %) and spaces.
Note: During this step, the system is not able to ensure that the password entered is the one actually requested by the modem, therefore please make sure you enter the correct password.
Also check that the box below is set to Enable.
Then click “Next” and wait a few seconds for verification.

Please fill in the following information:

Password (8-64 bytes)
 (Note: case sensitive)

 Show Password

Obtain an IP address
 automatically

IP address

Subnet mask

Gateway address

DNS server address

1 **2** 3 4

Figure 68 – Screen for entering the password of the wireless network (2)

9) Click “Next” again without ticking any of the options relating to the system security.

Enhance Security

You can enhance your system security by choosing the following methods

- Hide AP
- Change the encryption mode for AP
- Change the user name and password for Web server

1 2 **3** 4

Figure 69 - Screen for setting the security options (3)

10) Click “OK”.

Setting complete!

Click OK, the settings will take effect and the system will restart immediately.

If you leave this interface without clicking OK, the settings will be ineffective.



Figure 70 - Final configuration screen (4)

- 11) At this point, if the configuration of the adapter is successful, the last configuration screen will appear, and the telephone or PC will unpair from the inverter’s Wi-Fi network.
- 12) Manually close the web page with the Close key on the PC por remove it from the background of the telephone.

Setting complete! Please close this page manually!

Please login our management portal to monitor and manage your PV system. (Please register an account if you do not have one.)

To re-login the configuration interface, please make sure that your computer or smart phone

Web Ver:1.0.24

Figure 71 - Successful configuration screen

12.1.3. Verification

Wait two minutes after configuring the adapter and then go back to the Wi-Fi network selection screen to verify that the AP_***** network is no longer present. The absence of the Wi-Fi network in the list will confirm the successful configuration of the Wi-Fi adapter.



Figure 72 - Wi-Fi network search on Smartphone (iOS and Android); Access point of the Wi-Fi adapter is no longer visible

If the Wi-Fi network is still present in the list, connect to it again and enter the status page. Check the following information:

- a. Wireless STA mode
 - i. Router SSID > Router name
 - ii. Signal Quality > other than 0%
 - iii. IP address > other than 0.0.0.0
- b. Remote server information
 - i. Remote server A > Connected

Wireless STA mode		Enable
Router SSID	iPhone di Giacomo	
Signal Quality	0%	
IP address	0.0.0.0	
MAC address	98:d8:63:54:0a:86	
- Remote server information		
Remote server A	Not connected	

Figure 73 – Status screen

Status of LEDs present on the adapter

- 1) Initial status:
 - NET (left LED): off
 - COM (central LED): steady on
 - READY (right LED): flashing on

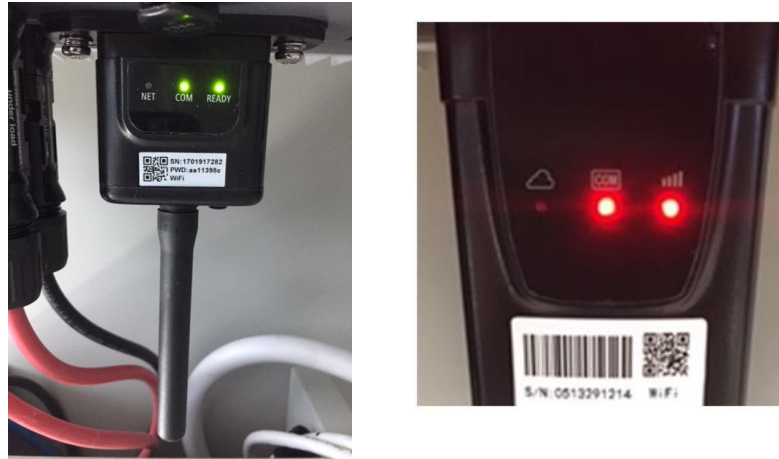

Figure 74 - Initial status of LEDs

- 2) Final status:
- NET (left LED): steady on
 - COM (central LED): steady on
 - READY (right LED): flashing on



Figure 75 - Final status of LEDs

If the NET LED does not light up or if the Remote Server A option in the Status page still shows “Not Connected”, the configuration was not successful, i.e. the wrong router password was entered or the device was disconnected during connection.

It is necessary to reset the adapter:

- Press the Reset button for 10 seconds and release
- After a few seconds, the LEDs will turn off and READY will start to flash quickly
- The adapter has now returned to its initial state. At this point, the configuration procedure can be repeated again.

The adapter can only be reset when the inverter is switched on.



Figure 76 – Reset button on the Wi-Fi adapter

12.1.4. Troubleshooting

Status of LEDs present on the adapter

1) Irregular communication with inverter

- NET (left LED): steady on
- COM (central LED): off
- READY (right LED): flashing on



Figure 77 - Irregular communication status between inverter and Wi-Fi

- Check the Modbus address set on the inverter:
Enter the main menu with the ESC key (first key on the left), go to System Info and press ENTER to enter the submenu. Scroll down to the Modbus address parameter and make sure it is set to 01 (and in any case, other than 00).

If the value is not 01, go to “Settings” (basic settings for hybrid inverters) and enter the Modbus Address menu where the 01 value can be set.

- Check that the Wi-Fi adapter is correctly and securely connected to the inverter, making sure to tighten the two cross-head screws provided.
- Check that the Wi-Fi symbol is present in the top right-hand corner of the inverter's display (steady or flashing).



Figure 78 – Icons on the display of LITE single-phase inverters (left) and three-phase or hybrid inverters (right)

- Restart the adapter:
 - Press the reset button for 5 seconds and release
 - After a few seconds, the LEDs will turn off and will start to flash quickly
 - The adapter will now be reset without having lost the configuration with the router

2) Irregular communication with remote server

- NET (left LED): off
- COM (central LED): on
- READY (right LED): flashing on



Figure 79 - Irregular communication status between Wi-Fi and remote server

- Check that the configuration procedure has been carried out correctly and that the correct network password has been entered.
- When searching for the Wi-Fi network using a smartphone or PC, make sure that the Wi-Fi signal is strong enough (a minimum RSSI signal strength of 30% is required during configuration). If necessary, increase it by using a network extender or a router dedicated to inverter monitoring.
- Check that the router has access to the network and that the connection is stable; check that a PC or smartphone can access the Internet
- Check that port 80 of the router is open and enabled to send data
- Reset the adapter as described in the previous section

If, at the end of the previous checks and subsequent configuration, Remote server A is still “Not Connected” or the NET LED is off, there may be a transmission problem at the home network level and, more specifically, that data between the router and server is not being transmitted correctly. In this case, it is advisable to carry out checks at the router level in order to ensure that there are no obstructions on the output of data packets to our server.

To make sure that the problem lies in the home router and to exclude problems with the Wi-Fi adapter, configure the adapter using the Wi-Fi hotspot function on your smartphone as a reference wireless network.

- **Using an Android mobile phone as a modem**

- Check that the 3G/LTE connection is active on your smartphone. Go to the Settings menu of the operating system (the gear icon on the screen with a list of all the apps installed on the phone), select “Other” from the Wireless and networks menu and make sure that the Network type is set to 3G/4G/5G.
- In the Android settings menu, go to Wireless & networks > Other. Select Mobile Hotspot/Tethering, and then enable the Wi-Fi mobile hotspot option; wait a few seconds for the wireless network to be created. To change the name of the wireless network (SSID) or your password, select Configure Wi-Fi hotspot.

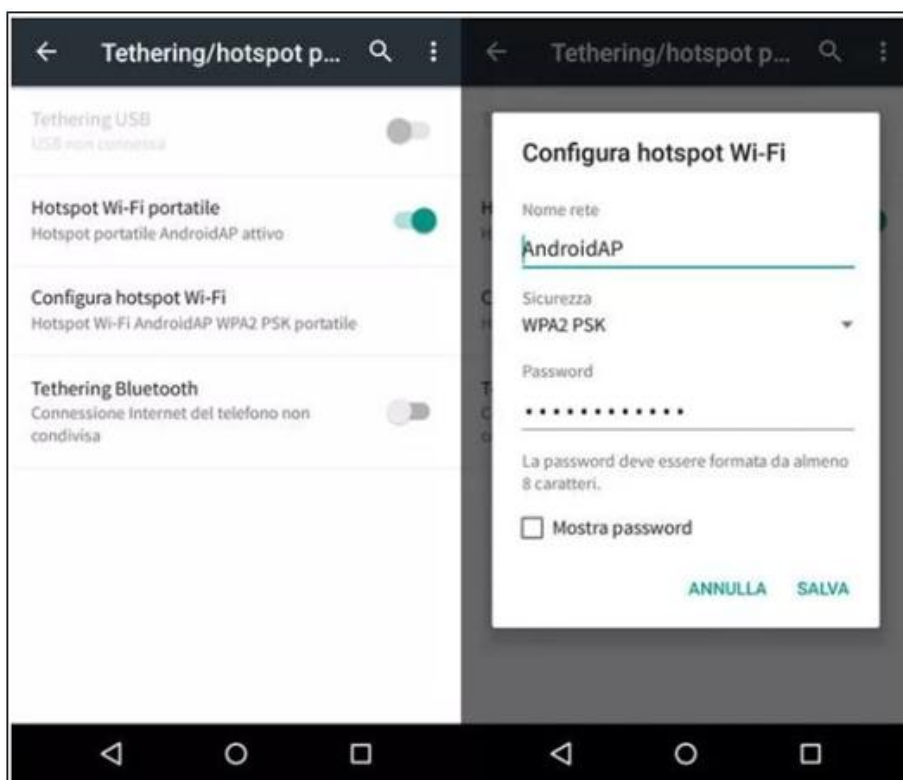

Figure 80 – Configuration of an Android smartphone as a hotspot router

- **Using an iPhone as a modem**

- In order to share the iPhone connection, verify that the 3G/LTE network is active by going to Settings > Mobile Phone, and making sure that the “Voice and data” option is set to 5G, 4G or 3G. To enter the iOS settings menu, click the grey gear icon on the home screen of your phone.
- Go to the Settings menu > Personal Hotspot and turn on the Personal Hotspot option. The hotspot is now enabled. To change the password of the Wi-Fi network, select Wi-Fi password from the personal hotspot menu.

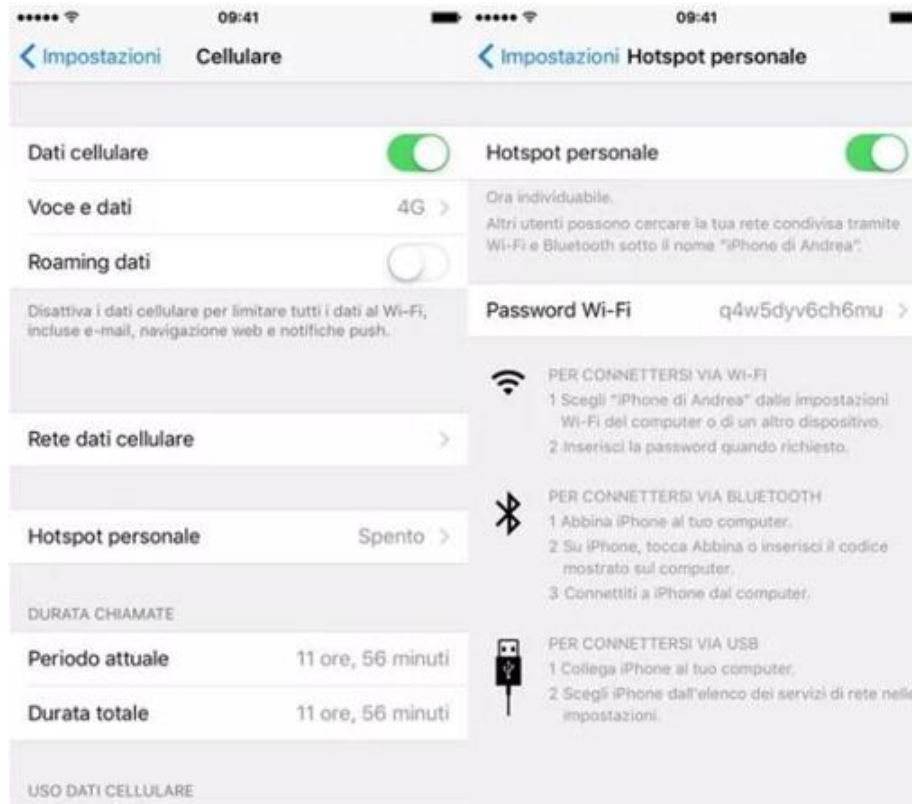

Figure 81 - Configuration of an iOS smartphone as a hotspot router

At this point, it is necessary to re-configure the Wi-Fi adapter using a PC or smartphone other than the one used as a modem.

During this procedure, when asked to select the Wi-Fi network, choose the one activated by the smartphone and then enter the password associated with it (which can be changed from the personal hotspot settings). If at the end of configuration, "Connected" appears next to "Remote Server A", then the problem is with the home router.

It is therefore advisable to check the brand and model of the home router you are trying to connect to the Wi-Fi adapter; some router brands may have closed communication ports. In this case, contact the customer service of the router's manufacturer and ask them to open port 80 (direct from the network to external users).

12.2. Ethernet adapter

12.2.1. Installation

Installation must be carried out for all inverters compatible with the adapter. However, the procedure is quicker and easier as there is no need to open the front cover of the inverter. Proper operation of the device requires the presence of a modem correctly connected to the network and in operation in order to achieve stable data transmission from the inverter to the server.

In order to monitor the inverter, the RS485 communication address must be set to 01 directly from the display.

Installation tools:

- Cross screwdriver
 - Ethernet adapter
 - Shielded network (Cat. 5 or Cat. 6) crimped with RJ45 connectors
- 1) Switch off the inverter following the procedure described in this manual.
 - 2) Remove the cover for accessing the Wi-Fi/Eth connector on the bottom of the inverter by unscrewing the two cross-head screws (a), or by unscrewing the cover (b), depending on the inverter model, as shown in the figure.



Figure 82 – Port of the Ethernet adapter

- 3) Remove the ring nut and the waterproof cable gland from the adapter to allow the network cable to pass through; then insert the network cable network into the appropriate port on the inside of the adapter and tighten the ring nut and cable gland to ensure a stable connection.

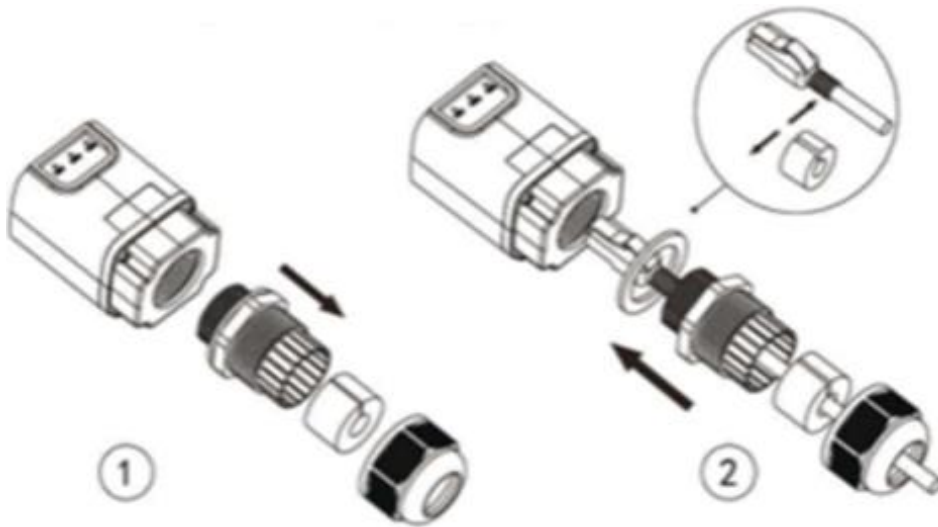

Figure 83 – Inserting the network cable inside the device

- 4) Connect the Ethernet adapter to the appropriate port, making sure to follow the direction of the connection and ensure correct contact between the two parts.

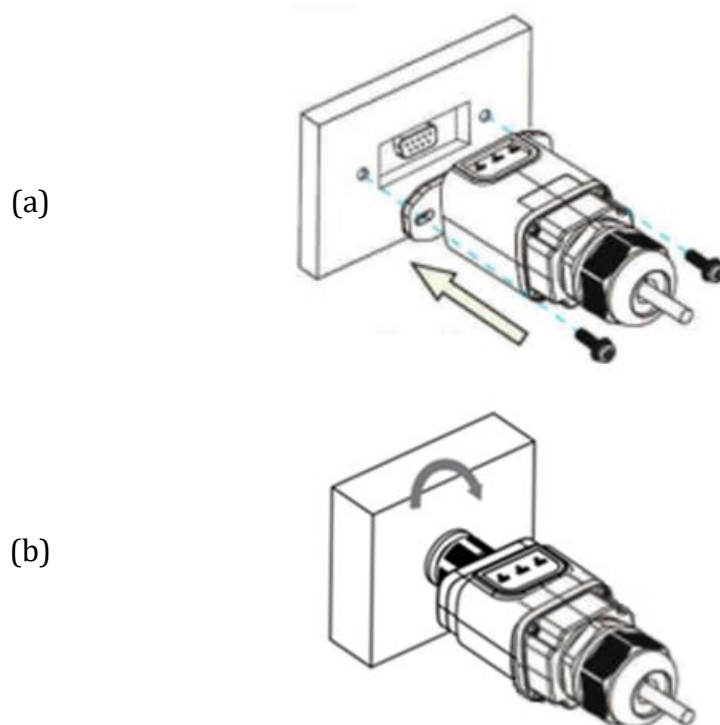

Figure 84 – Inserting and securing the ethernet adapter

- 5) Connect the other end of the network cable to the ETH output (or equivalent) of the modem or a suitable data transmission device.

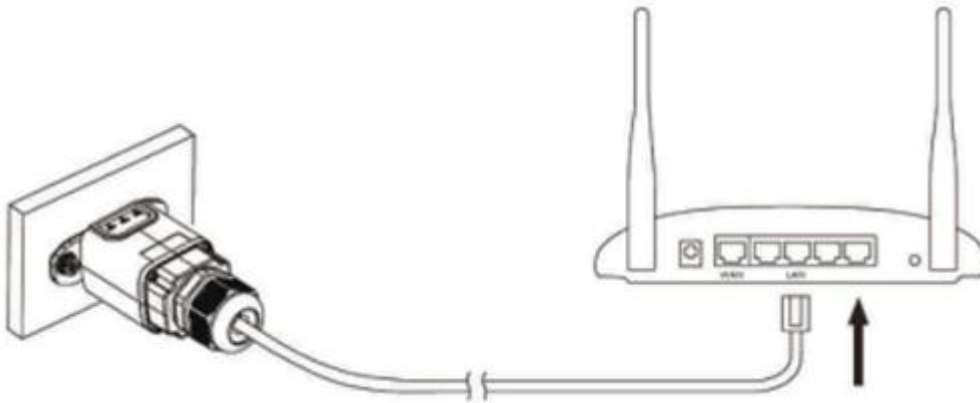

Figure 85 – Connecting the network cable to the modem

- 6) Switch on the inverter by following the procedure described in the manual.
- 7) Unlike Wi-Fi cards, the Ethernet adapter does not need to be configured and starts transmitting data shortly after the inverter is switched on.

12.2.2. Verification

Wait two minutes after installing the adapter, and check the status of the LEDs on the device.

Status of LEDs present on the adapter

- 1) Initial status:
 - NET (left LED): off
 - COM (central LED): steady on
 - SER (right LED): flashing on



Figure 86 - Initial status of LEDs

- 2) Final status:
- NET (left LED): steady on
 - COM (central LED): steady on
 - SER (right LED): flashing on



Figure 87 - Final status of LEDs

12.2.3. Troubleshooting

Status of LEDs present on the adapter

- 1) Irregular communication with inverter
 - NET (left LED): steady on
 - COM (central LED): off
 - SER (right LED): flashing on



Figure 88 - Irregular communication status between the inverter and adapter

- Check the Modbus address set on the inverter:
Enter the main menu with the ESC key (first key on the left), go to System Info and press ENTER to enter the submenu. Scroll down to the Modbus address parameter and make sure it is set to 01 (and in any case, other than 00).
If the value is not 01, go to “Settings” (basic settings for hybrid inverters) and enter the Modbus Address menu where the 01 value can be set.
- Check that the Ethernet adapter is correctly and securely connected to the inverter, making sure to tighten the two cross-head screws provided. Check that the network cable is correctly inserted into the device and modem, and that the RJ45 connector is correctly crimped.

- 2) Irregular communication with remote server
 - NET (left LED): off
 - COM (central LED): on
 - SER (right LED): flashing on



Figure 89 - Irregular communication status between the adapter and remote server

- Check that the router has access to the network and that the connection is stable; check that a PC can access the Internet

Check that port 80 of the router is open and enabled to send data.

It is advisable to check the brand and model of the home router you are trying to connect to the Ethernet adapter; some router brands may have closed communication ports. In this case, contact the customer service of the router's manufacturer and ask them to open port 80 (direct from the network to external users).

12.3. 4G adapter

The ZCS 4G adapters are sold with a virtual SIM integrated into the device with data traffic fee included for 10 years, which is adequate for the proper transmission of data to monitor the inverter.

In order to monitor the inverter, the RS485 communication address must be set to 01 directly from the display.

12.3.1. Installation

Installation must be carried out for all inverters compatible with the adapter. However, the procedure is quicker and easier as there is no need to open the front cover of the inverter.

Installation tools:

- Cross screwdriver
- 4G adapter

- 1) Switch off the inverter following the procedure described in this manual.
- 2) Remove the cover for accessing the Wi-Fi/ GPRS connector on the bottom of the inverter by unscrewing the two cross-head screws (a), or by unscrewing the cover (b), depending on the inverter model, as shown in the figure.



Figure 90 – Port of the 4G adapter

- 3) Insert the 4G adapter into the appropriate port, making sure to follow the direction of the connection and ensure correct contact between the two parts. Secure the 4G adapter by tightening the two screws inside the package.

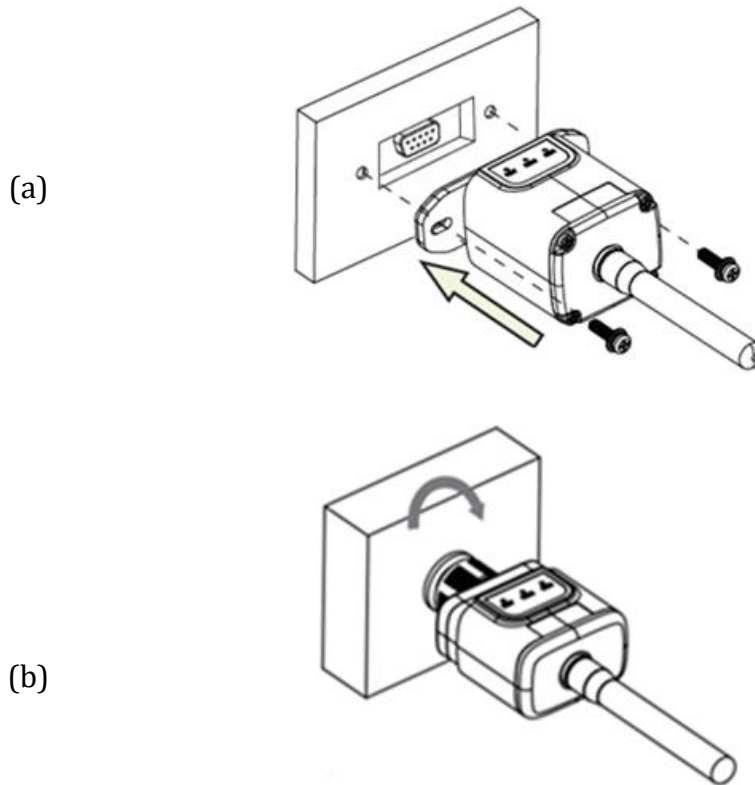

Figure 91 - Inserting and securing the 4G adapter

- 4) Switch on the inverter by following the procedure described in the manual.
- 5) Unlike Wi-Fi cards, the 4G adapter does not need to be configured and starts transmitting data shortly after the inverter is switched on.

12.3.2. Verification

After installing the adapter, within the next 3 minutes check the status of the LEDs on the device to ensure that the device is configured correctly.

Status of LEDs present on the adapter

1) Initial status:

- NET (left LED): off
- COM (central LED): flashing on
- SER (right LED): flashing on



Figure 92 - Initial status of LEDs

2) Registration:

- NET (left LED): flashes rapidly for about 50 seconds; the registration process takes about 30 seconds
- COM (central LED): flashes rapidly 3 times after 50 seconds

3) Final status (approx. 150 seconds after the inverter has started):

- NET (left LED): flashing on (off and on at equal intervals)
- COM (central LED): steady on
- SER (right LED): steady on



Figure 93 - Final status of LEDs

Status of LEDs present on the adapter

1) Irregular communication with inverter

- NET (left LED): on
- COM (central LED): off
- SER (right LED): on



Figure 94 - Irregular communication status between inverter and adapter

- Check the Modbus address set on the inverter:
 Enter the main menu with the ESC key (first key on the left), go to System Info and press ENTER to enter the submenu. Scroll down to the Modbus address parameter and make sure it is set to 01 (and in any case, other than 00).

If the value is not 01, go to “Settings” (basic settings for hybrid inverters) and enter the Modbus Address menu where the 01 value can be set.

- Check that the 4G adapter is correctly and securely connected to the inverter, making sure to tighten the two cross-head screws provided.

2) Irregular communication with remote server:

- NET (left LED): flashing on
- COM (central LED): on
- SER (right LED): flashing on



Figure 95 - Irregular communication status between the adapter and remote server

- Check that the 4G signal is present in the installation location (the adapter uses the Vodafone network for 4G transmission; if this network is not present or the signal is weak, the SIM will use a different network or will limit the data transmission speed). Ensure that the installation location is suitable for 4G signal transmission and that there are no obstacles that could affect data transmission.
- Check the status of the 4G adapter and that there are no external signs of wear or damage.

13. Warranty terms and conditions

To view the “Warranty Terms and Conditions” offered by ZCS Azzurro, please refer to the documentation inside the product box and on the website www.zcsazzurro.com.